



SF557 San Franciscan Assembly Instructions

© 1999 Dura-Craft, Inc.

Building a doll house is fun! How long it takes you to build the San Franciscan will depend on who you are and what a "finished" doll house means to you. If you are simply looking for an unpainted structure that your little girl can enjoy, this kit will go together fast. However, if you want a show piece with paint, wallpaper, electric lights, etc., that will lengthen the assembly process. Some of you will blast through this project in short order, but the rest of us will enjoy dawdling along and admiring our work as we go.

Save the box. The picture will be a good reference for what your kit should look like.

Don't get ahead. The order of events is important.

Release the parts gently. Parts in the 1/8 inch plywood boards must be removed by exerting gentle pressure. A few will require that you cut them loose with your knife. Cut from the front side of the board (the side with the most visible cut marks), and please be careful.

Glue. Everyone has a favorite kind of glue. Most glues work fine if they are recommended for woodworking or porous materials. We recommend a yellow woodworking glue on the main structure of the house and a "tacky" craft glue on the trim pieces.

Dry fit each piece before gluing. This will ensure that you have the right piece for the right place and that you will make valuable judgments about where to put the glue.

Replacement parts. Dura-Craft, Inc. has gone to great lengths to grade and sort pieces for quality and workmanship. We think you will be pleased. However, if you discover a faulty, missing, or damaged part, Dura-Craft, Inc. will quickly replace it, even if the damage is caused by improper assembly. We have included a "Missing and Broken Parts Replacement Form" to assist you.

Drawings. The progressive construction pictures in this instruction booklet are *not* photographs. They are 3D drawings constructed piece by piece on a computer. As a matter of convenience, some of the detail has been deliberately left out of the drawings. This won't be a problem if you keep in mind that the drawings are designed to give you the "big picture" and should not be subjected to undo analysis.

Painting. You should keep in mind that these instructions are designed to help you construct the basic house kit. If it is your intention to paint, wall paper, etc., you will need to make your own reasonable judgments about when these procedures will best be performed. Remember that we don't know whether you are going to use electrical wiring under your wallpaper (for example), or what kind of wiring procedure you intend to use.

However, as a general rule, if you are not electrifying your doll house, it is much easier to paint and/or wallpaper as you go along. Because glue holds best when paint is not involved, we have found it best to build the basic shell of the house before starting to paint.

Best results can be obtained by using a good sealer before applying paint. Latex paint is preferred.

IMPORTANT! First, familiarize yourself with the parts pages at the end of these instructions. If you know how to identify parts before you begin, you will save time and this will be a more pleasant building experience.

Base (Foundation & first floor)

1. Locate the First Floor (SF1) and First Floor Extension (SF2). Edge glue these two pieces together as shown.

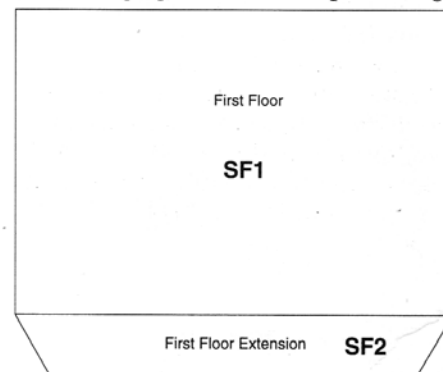

TIP: Some pieces may look a lot like other pieces. It is a good idea to measure each piece and compare it to the parts list in order that you not glue the wrong piece in the right spot.

2. Locate the seven Foundation pieces – SF3, SF4, SF5(2),

SF6, and SF7(2). Turn the first floor assembly (from step 1.) face down on your work surface. Beginning with the Back Foundation (SF3), glue all seven foundation pieces to the bottom of the first floor assembly as shown. Glue the edges of pieces where they meet, also. The outside edge of each piece should be flush with the outside edge of the first floor assembly. The Center Support (SF4) should be centered.

BOTTOM VIEW

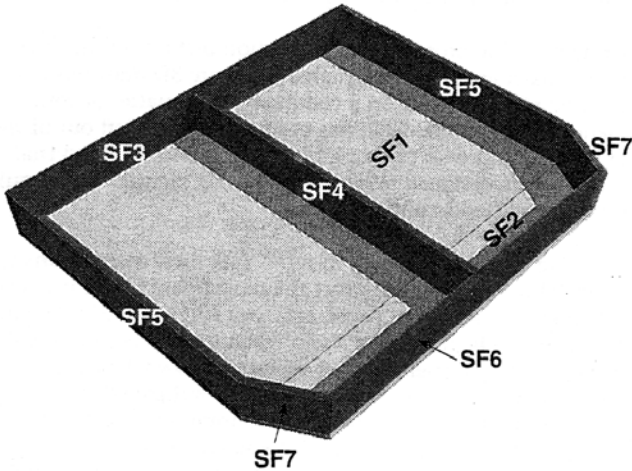

TIP: A good carpenter rarely relies on gravity or friction to produce a suitable bond between pieces. To force a tight fit while glue dries, use clamps, tape, or brads. Because it is quick and easy, we prefer masking tape. Wipe away excess glue while it is still wet.

This entire building can be put together in a hurry if you use glue and tape strategically, allowing the tape to do the work until the glue dries. However, if you are in less of a hurry, there are some advantages to allowing the glue to dry before proceeding to the next step (except where indicated otherwise). We recommend the "let it dry method" unless you have a deadline that cannot be extended.

Walls & Floors

1. First, locate the Second and Third Floor SF8(2), Trapezoid Floor Extensions SF9(3), and Third Floor Extension Right (SF10). The stairway hole in the floors (SF8) are centered side to side, but they are not centered front to back – they should be 5" from the back edge as shown. Edge glue pieces together as shown. IMPORTANT: Notice that the Third Floor Extension Right (SF10) extends beyond the right edge of the Third Floor by 1/4".

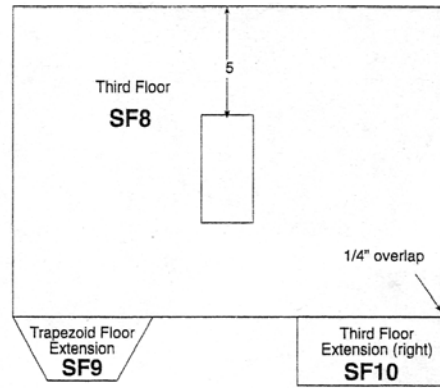
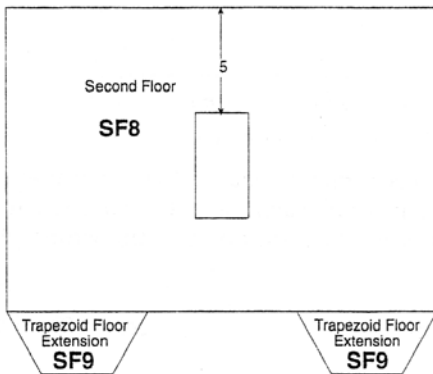

2. Let the floor assemblies dry before proceeding. Find the Left & Right Side Walls - SF11(2). Glue the second floor assembly into the dados (grooves) that run through the middle of the two walls. The back edge of the second floor should be flush with the back edge of the two walls. **This can be most easily accomplished if you stand the walls and floors on their back edges while assembling and taping.** Tape securely. Glue the third floor assembly into the rabbets (edge grooves) at the upper edges of the two walls. Tape securely.

Use a square or a piece of typing paper to check the squareness of the assembly before the glue dries. See the illustration for proper orientation of parts.

Important Notice: Please take a minute to study the direction of the siding on the outside of the walls. It is easy to accidentally get it up-side-down.

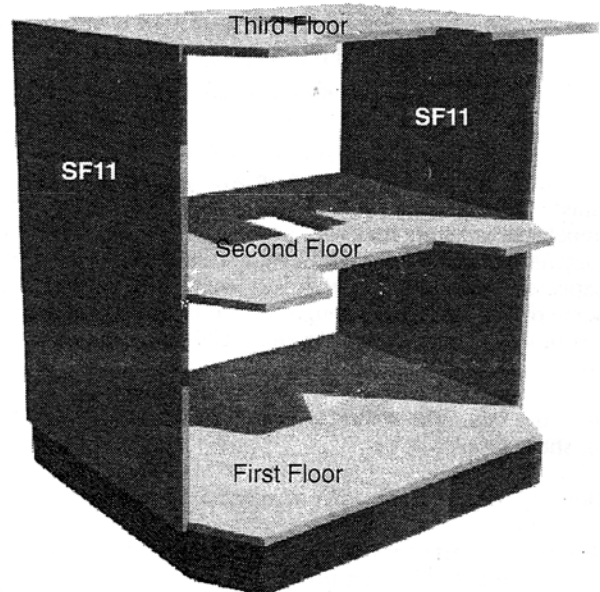

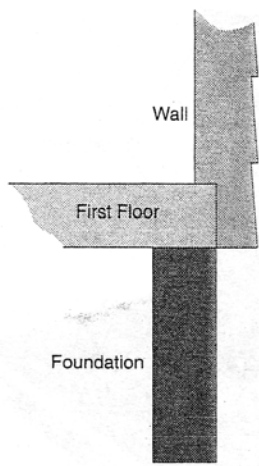

3. Glue the assembly to the first floor (flush at the back) and secure it in position. Clamps work best, if you have them.

The notches at the bottom of the walls fit onto the floor in such a manner that the bottom of the wall covers the edge of the floor.

4. Make sure everything is square before the glue dries.

5. Locate the three Bottom

Tower Walls - SF12(2), SF13(1). Locate the Bay/Tower Template (1/8" plywood).

Look at the picture at the beginning of these instructions or on the box. Notice which side of the house is the tower side and which is the bay window side.

First, fit the Bottom Tower Walls (SF12) to the first floor by gluing the rabbets (grooves) at the bottom of each wall to the edge of the floor (see illustration). The angled edges of the two pieces should fit together tightly. NOTE: The back edge of the leftmost piece will not fit exactly to the edge of the side wall. This is correct. Later we will place a piece of molding which will hide the overhang.

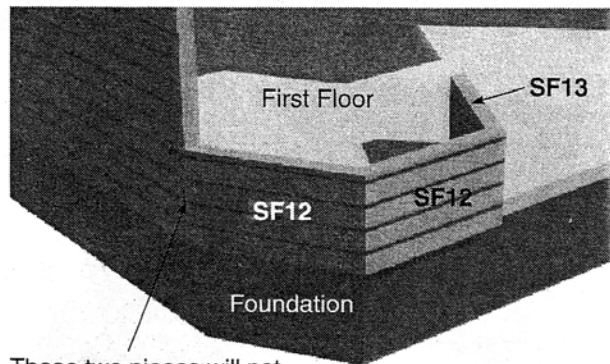

These two pieces will not fit perfectly at this joint. This is not a problem.

Next, place the Bottom Tower Wall (right cant) - SF13 on top of the floor and against the Bottom Tower Wall (SF12). Use the Bay/Tower Template to obtain the proper angle. Lay the template on the floor and slide it snugly against the inside edges of the two Bottom Tower Walls (SF12). Then glue the Bottom Tower Wall Right Cant (SF13) against the edge of the template. Carefully remove the template without disturbing the position of the wall. Let the glue dry. **Keep the Bay/Tower Template handy - it will be used several times.**

6. Using the exact same technique working in the opposite direction, locate and position the three Bottom Bay Walls - SF12(2), SF13(1) on the right side of the first floor.

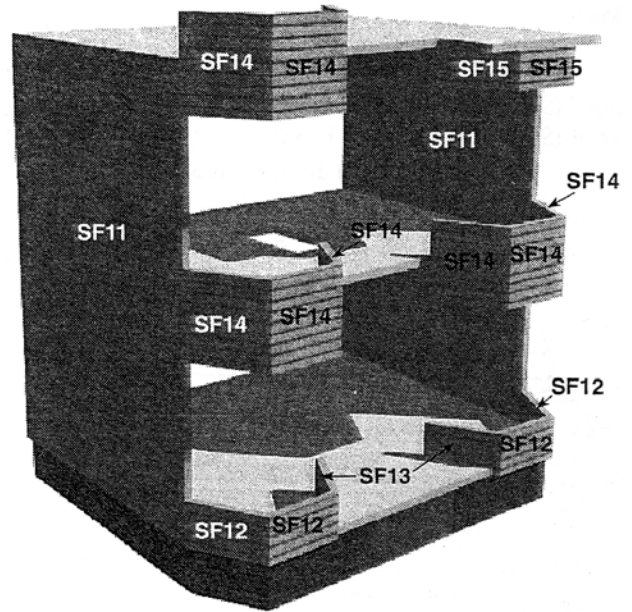

7. Locate and position the Second & Third Floor Tower Walls SF14(3 each), the Center Bay Walls SF14(3), and the Top Bay Walls SF15(3). Each of these groups should be glued together off of the house using the Bay/Tower Template. When the glue is dry, place them on the house. Use the dado (groove) to position the walls on the appropriate floors.

The Top Bay Walls (SF15) will be glued to the underside of the Third Floor Extension (SF10) so that the front edge of the center piece is flush to the front edge of the extension. Tape until dry. NOTICE: Take one last look to make sure that the siding is right side up on all of the walls.

8. Locate the two Entry Walls (SF16) and glue them to the back edges of the tower and bay walls that you just glued in steps 6 & 7. This works best if you work from the back of the house and place the bottom end in position first, then swing the top end into position. It may require some pressure to get the top end to seat properly. Make sure the Entry Walls are centered. Be sure to glue the tops and bottoms of the walls, also, since these two pieces provide a great deal of stability to the house.

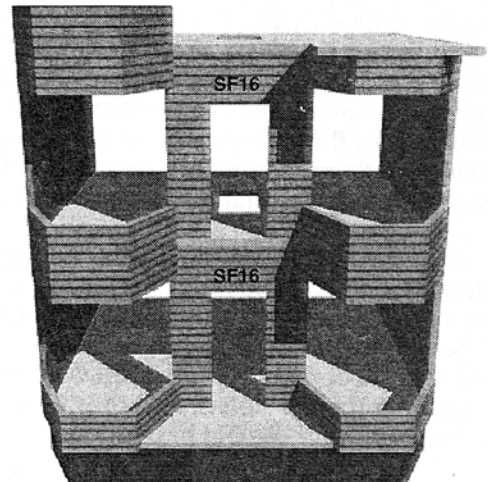

Roof

1. First, locate the Right Main Roof (SF17), the Left Main Roof (SF18), the Right Gable Roof (SF21), the Left Gable Roof (SF22), and the six Tower Roof pieces (1/8" plywood).

Dados (grooves) are on underside.

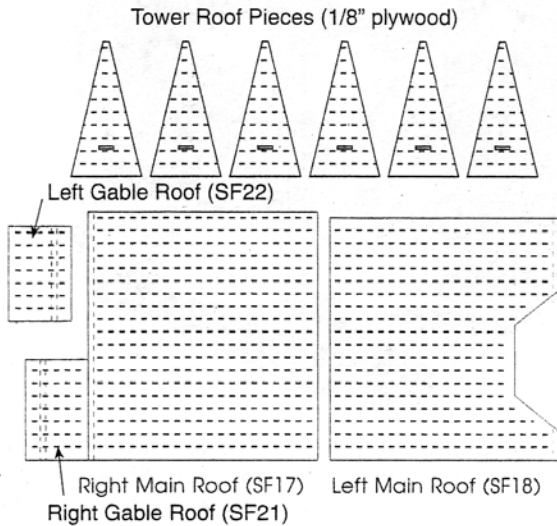

2. You will need to mark all roof pieces with pencil lines so you will be able to properly position the shingles when you have your house completed. Start at the bottom edge of each roof piece and measure up 7/8 inch at both the right and left edges. Using a straight edge, mark a horizontal pencil line all the way across the piece. Then repeat the process every 7/8 inch until you reach the top of the piece.

The illustration shows which pieces to find and the proper orientation for each roof piece.

3. Lay both main roof pieces (SF17 and SF18) flat on your work surface, underside up. Make sure that the rabbet (groove) on each piece is facing up and that both pieces have the rabbet at the same end. Place a pencil line 1-3/16" from the edge of each piece as shown. Locate two pieces of triangle molding (5-162), one 14-1/2" piece and one 14-1/8" piece. Glue them along the pencil line as shown. The widest side of the triangle should be glued to the roof. **IMPORTANT:** The long piece of 5-162 glues to the Left Main Roof (SF18) and the front edge should be flush to the edge of the roof (ignore the rabbet notch). The short piece of 5-162 glues to the Right Main Roof (SF17) and should be flush to the edge of the rabbet notch. When properly positioned, the back end of these two pieces will be equal distances from the back of the roof.

4. With the Right Main Roof (SF17) flat on your work surface, glue the Left Main Roof (SF18) on the Right Main Roof at a 90° angle. This means the Left Main Roof (SF18) will be standing exactly straight up on the top edge of the Right Main Roof (SF17). It is critical that this be exactly 90° and that the top surface of SF18 is flush to the top edge of SF17. Tape or hold in position.

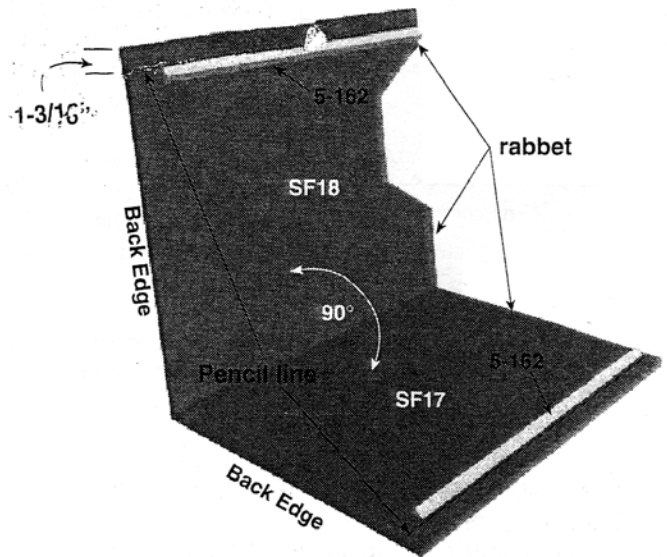

5. Before the glue dries completely, glue the Main Gable (SF19) into the rabbets (grooves) at the front edges of the two main roof pieces. Be very careful to get this piece oriented correctly – the *longest* edge (15-3/8") fits into the rabbet (groove) in the Right Main Roof (SF17).

The Main Gable (SF19) will help ensure that the Main Roof pieces are square to each other, but it is up to you to be certain that this is the case before the glue dries. If you have a carpenter's square, now is the time to use it, but a piece of typing paper will work also, if you are careful. Again, tape everything into place until the glue dries.

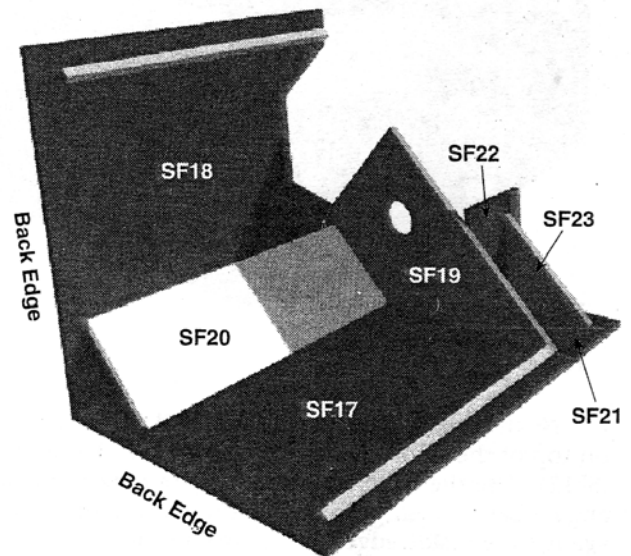

6. When the glue from step 5. above is dry, glue on the Attic Floor (SF20). The beveled edges fit against the underside of the roof pieces, and the front edge glues against the Main Gable (SF19). This piece will add a great deal of stability to the roof and it will make the roof assembly much easier to handle.

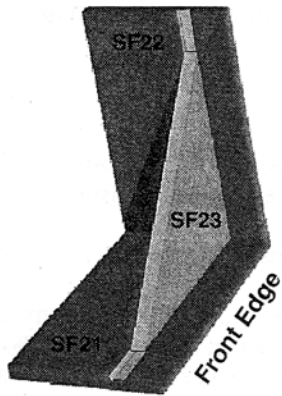

7. Locate the Small Gable (SF23) and the Right and Left Gable Roofs (SF21 & SF22). Glue them together as shown, with the edge of SF22 glued against the underside of SF21. Glue the assembly to the front edge of the Right Main Roof (SF17) and the Main Gable (SF19). See illustration above.

8. When the glue on the entire roof assembly is dry, turn it over and put it in place on top of the third floor. The two

triangle moldings (5-162) will sit on the third floor at the outside edges.

Check the following:

- The front surface (face) of the Small Gable (SF23) should be flush to the front edge of the Third Floor Extension (SF10).
- The front surface (face) of the Main Gable (SF19) should be flush to the front edge of the Third Floor (SF8).
- The back end of the triangular molding (5-162) should be flush to the back edge of the Third Floor (SF8).
- The under side of the two main roof pieces should be touching (or nearly touching) the top outside edge of the two side walls.
- Temporarily position the Third Floor Partition (SF29). If everything else is in place, the Third Floor Partition will fit nicely between the third floor and the attic floor.

Roof Front View

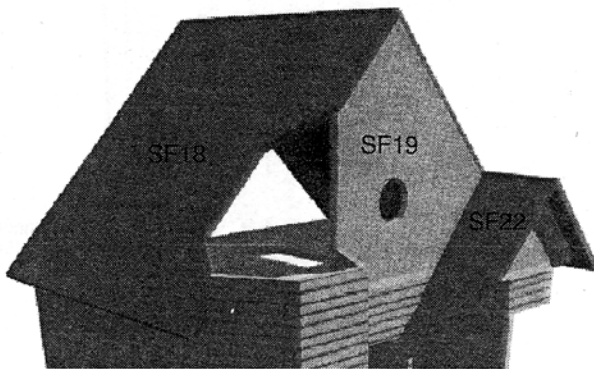

9. When you are certain that the roof fits properly, glue it into position and tape it until it dries.

Roof Back View

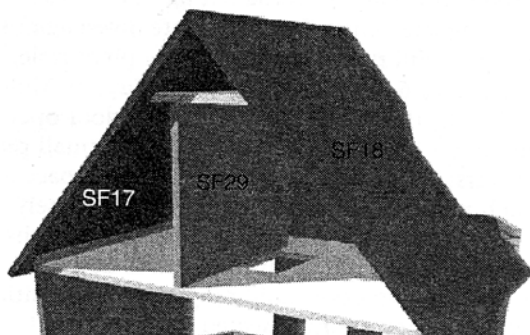

Eaves

- Edge glue the Right Eaves (SF31) against the front edge of the Right Main Roof (SF17) with its lower end against the top edge of the Small Gable Roof (SF21). Notice: "Eaves" is a plural noun that has no singular form – no such word as eave. The Right Eaves is only one piece.
- Edge glue the Left Eaves (SF32) against the front edge of the Left Main Roof (SF18) with its top end against the under side of the Right Eaves (SF31). Glue the Lower Left Eaves (SF33) into position at the bottom edge of the Left Main Roof (SF18).
- Using a straight edge (ruler), extend your pencil lines from the main roof pieces onto the eaves.

Tower Top

- Re-locate the Bay/Tower Template (1/8" plywood). This is the template piece that you used earlier to create the proper angles for the bay and tower walls. Place the template flat on your work surface, and form the 3 Top Tower Walls (SF24) around the template. Glue them on the beveled edges, tape them securely, and remove the template without disturbing the angles.

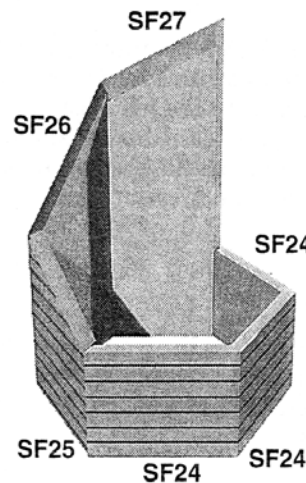
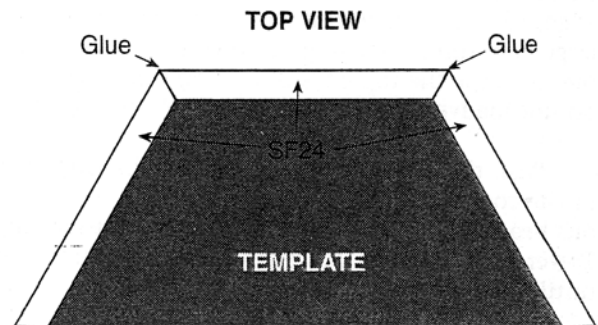

- Repeat the process with the three Tower Back Walls (SF25-27). In this case, you will need to stand the walls on their tops until the glue dries. Once again, make sure that the siding is facing the right direction on each piece.

- With the two assemblies on their tops, glue them together to form a hexagon. Use tape to hold the assembly together while the glue dries. When the glue has dried, turn this "tower top assembly" upright and glue it to the Left Main Roof (SF18).

The front edges of SF25 and SF27 must be flush to the front edge of the Left Main Roof (SF18). Line up the left edge of SF27 with the left edge of the third floor tower

wall (SF14).

4. Measure the distance from the top of the third floor tower walls (SF14) to the bottom of the Top Tower Walls (SF24). It should be approximately 6-1/8 inches. Adjust the top tower assembly *slightly* up or down the roof to get the gap correct.

Tower Roof

1. Locate the six Tower Roof Pieces and the Tower Roof Support (1/8" plywood). Lay the Tower Roof Pieces face down on your work surface (the lines that you drew earlier should not be visible). Tape them together.

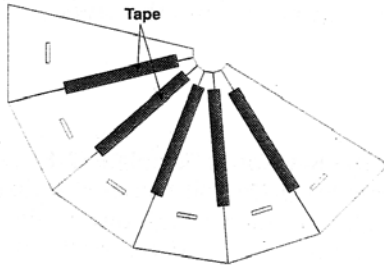

2. Turn the two untaped edges around toward each other until they come together forming a cone (the lines that you drew are on the *outside* of the cone). Tape these two edges together. With this cone standing upright on its large end, run a bead of glue down each joint between pieces. Tape the top ends of the cone together so that they do not inadvertently spread apart. Let the glue dry.

3. Push the Tower Roof Support into the large, open end of the cone until the tabs snap into the slots. Run a generous bead of glue all the way around the outside edge of the Tower Roof Support. Hold this assembly upside down until the glue dries.

4. Set the Tower Roof Assembly aside until later.

Room Partitions

1. Locate and glue the three Room Partitions, SF28(2) and SF29. Use the box photo as a guide for placement. The partitions should be flush with the left edge of the stairwell as viewed from the back of the house, and the back edge of the partition should be flush with the back edge of the floors. Take some time to ensure that the partitions are plumb.

Balcony Floor

1. Glue the Balcony Floor (SF30) to the front edge of the Second Floor (SF8) and against the inside walls of the bay and tower walls. Make sure that it is level and then tape it in place until the glue dries.

NOTICE: This completes the assembly of the main structure of the house. If you have not already begun painting, now is the time to begin before we start putting on things that are difficult to paint around. Best results can be obtained by using a good sealer before applying paint.

Latex paint is preferred. DO NOT paint the foundation yet.

Doors

1. Follow the diagram to construct the balcony door assembly. Painting will be easiest if accomplished before assembly.
 - a. Assemble door front, back, glass & decor as shown in diagram.
 - i. Punch the scrap pieces out of the Balcony Door Front and Back (1/8" plywood, Sheet SFE). Lay the Door Back best side down. Run a *thin* bead of glue around the opening in the Door Back (on the flat surface outside the hole, not on the inside edge of the hole). Place the appropriate piece of door glass on the Door Back (see box photo to determine which glass goes where).
 - ii. Run a bead of glue around the back side of the Door Front and center it on top of the glass and Door Back. Weight down or tape until dry.
 - iii. Lay the door flat on its back and install the door knob (6-17) on the right side. Push the pin straight into the plywood. See box photo for best position.

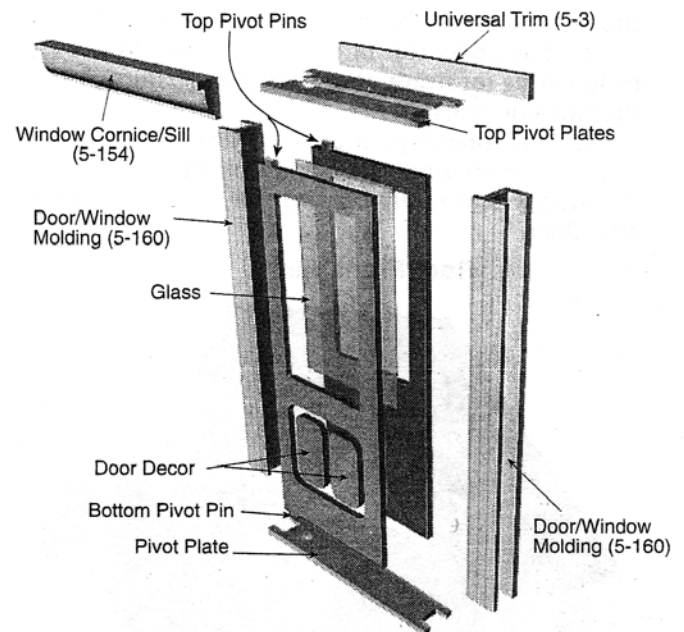

- b. Locate a bottom pivot plate (1/8" plywood – sheet SFH) and place it into the bottom of the balcony doorway with the forked ends straddling the wall on each side. The hole in the pivot plate is on the left as viewed from the front of the house. Glue the pivot plate down against the floor, being careful not to get glue in the pivot hole.

- c. Cut two 6-3/4" pieces of Door/Window Molding (5-160). Dry fit these into the sides of the door opening. They should be 1/8" short at the top. Cut a small piece of scrap Universal Trim (5-3) and slip it into the space at the top of each molding to make sure that it fits loosely. If it fits too tightly, sand the top end of the moldings slightly until the universal trim slips into position easily.

- d. Glue the two door molding pieces into position. Make sure that they are fully seated against the sides of the door opening and that the decorative side of the molding

is on the outside.

e. Working from the front of the house, glue 1/2 of a top pivot plate above the two door moldings. The half hole must be directly above the hole in the bottom pivot plate.

NOTICE: Doors will swing best and install easier if the edges of the pivot pins at the top and bottom of the door are sanded or trimmed so that the pins are approximately round. Do this before proceeding.

Also, sand the hinged edge of the door into a rounded shape to give it clearance to swing properly.

TOP VIEW OF DOOR (hinged side)

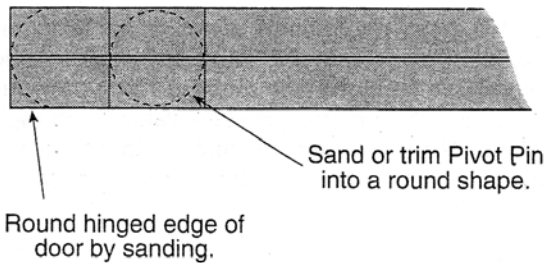

f. Now working from the back of the house, place the bottom pivot pin on the door assembly into the hole in the bottom pivot plate, and the top pivot pin into the half hole in the top pivot plate. While holding the door in position, glue in the back half of the top pivot plate. Again, be careful to keep glue out of the pivot hole.

g. Cut and glue a 4" piece of Universal Trim (5-3) at the top of the door on the inside to form the inside top door molding. This piece will rest against the top ends of the side door moldings, and it will overhang slightly at the ends in the fashion of many old houses.

h. Cut and glue a piece of Cornice/Sill molding (5-154) to form the exterior top door molding. This piece can be mitered at the ends if desired (see box photo). The length of this piece will depend on whether you decide to have square ends or mitered ends, and on what angle you choose to miter. We suggest that you decide your method first, then measure carefully before cutting.

2. Using the same technique, you may install the entry door (oval window) now, too.

Double Hung Windows

1. Follow the diagrams to construct the double hung windows. Painting will be easiest if done before assembly. However, don't paint on the back sides of objects where glue will be applied, and don't paint in the sliding grooves of the Window Molding (5-161) if you want the windows to slide properly.

a. Punch the centers out of a rectangular Slider and Frame (1/8" plywood). Sliders and Frames for the top window of each pair must match – arched top with arched top, round top with round top, and square top with square top.

Lay the Slider best side down. Run a thin bead of glue around the opening in the Slider (on the flat surface outside the hole, not on the inside edge of the hole). Place a

piece of glass on the slider (see box photo to determine which window glass goes where). Get the proper window glass with the proper top – arched, round, and square.

b. Run a bead of glue around the back side of the frame and center it on top of the glass and slider. Weight down or tape until dry.

c. Repeat this process for all 30 of the Slider/Frame/Glass groups. Notice that the glass in the bottom group is not the same as in the top (see box photo).

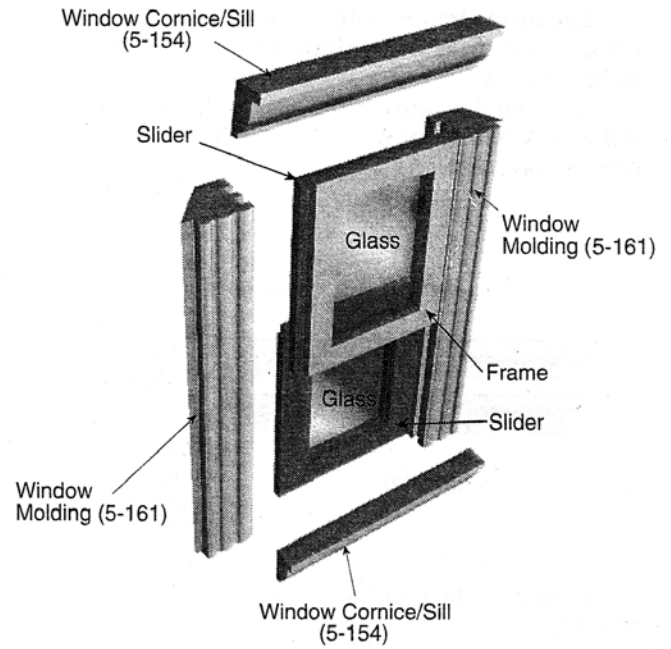

TOP VIEW

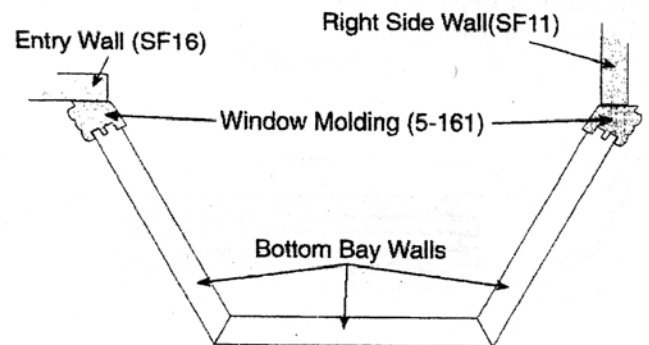

d. Cut six 6-1/8" pieces of Window Molding (5-161). Glue one piece in the bottom bay window opening with its beveled edge against the front face of the Entry Wall (SF16). The inside edge should overhang the inside edge of the Bay Wall. The outside edge (decorative) will also overhang the outside edge of the Bay Wall (see diagram).

Place the next piece on the other side of the opening with its beveled edge against the front edge of the Right Side Wall (SF11). These pieces should fit snugly between the Bottom Bay Walls and the Center Bay Walls (sand to fit). Let glue dry.

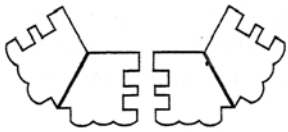

e. Glue the remaining four pieces together in pairs as shown. Make sure they are even at top and bottom.

f. Select two of the window groups that you made in steps a-c. Check the box photo to determine which windows fit in this position. Place the right side sliders into the grooves of the window molding at the right side of the window opening.

The inside frame (bottom) faces inward and has clear glass. The outside frame (top) faces outward and has silk screened glass.

Both window groups can rest at the bottom of the Window Molding for now. They will sit on top of the Bottom Bay Walls.

TOP VIEW

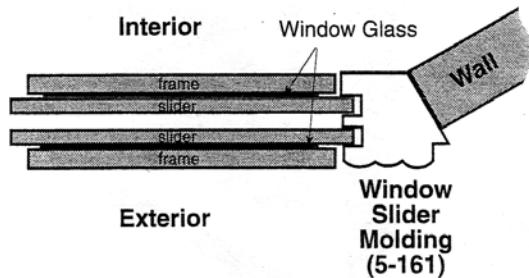

g. Repeat the process on the left side of the window opening.

h. Now comes the tricky part. It will seem awkward for this first effort, but it will be easier when you do it again on the remaining window openings. For this first effort, we recommend that you try it first without glue so that you get the feel of how it is supposed to work.

Take your two double moldings that you glued together in step e. and place two window groups between them in the sliding slots.

TOP VIEW

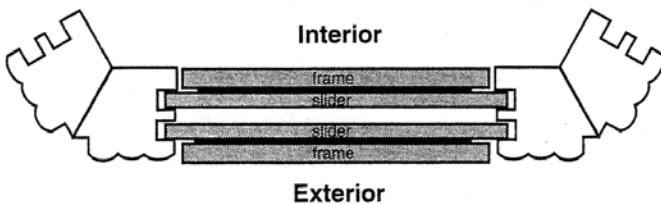

While holding this assemblage together, angle the left molding into the house and align the two previously placed windows on the left side into the slots in the left double molding.

When the left side windows are in place, swing the right side double molding inward (toward the house). Pull the front edges of the right side windows outward slightly until they slip into the slots of the right side double molding.

Gently push the whole assembly inward until everything lines up properly. Leave about 1/8" of the decorative side of the molding overhanging the walls.

Now that you have the feel of the process, do it

again with glue on the upper and lower ends of the two double moldings. Wipe away excess glue.

i. Cut and glue the Window Cornice (5-154) on the outside. It fits against the top end of the Window Molding (5-161). This piece can be mitered (30°) at the ends if desired so that all of the cornice pieces fit together (see box photo). Repeat on the inside if desired.

j. Cut and glue the Window Sill (5-154) using the same technique that you used with the window cornice pieces.

k. Repeat steps d through i for the remaining window openings in the bay and tower. **Be careful to get the correct silk screened windows in the correct places.**

Note: We are of the opinion that it makes little sense for the top window in a double hung doll house window to be movable. We designed it to move so that you would have the option, but there may be some value to gluing it in place and letting the bottom window do the moving. Your choice.

Oxeye Window

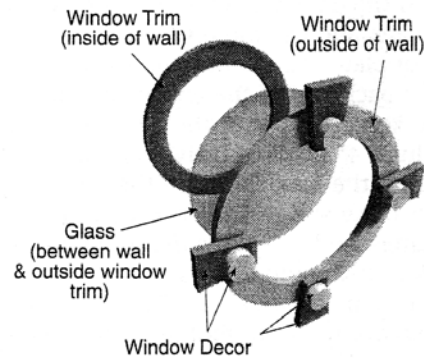

1. Use the illustration as a guide to construct the oxeye window. Painting will be easiest if accomplished before assembly. Window glass goes between the exterior round trim and the outside of the wall. The window decor pieces are not shown in the

box photo – they are optional.

Corner Trim Pieces

1. Locate some corner trim molding (5-8) and some Universal Trim (5-3). Cut two pieces of Corner Trim molding (5-8) to cover each of 2 exterior corners – the back right corner and the back left corner. Cut the top ends at a 45° angle to fit the under side of the roof.

Cut two pieces of Universal Trim (5-3) to fit vertically on each side wall along the back, outside edge of the bay windows and tower windows.

Porch Decor

1. Cut two 3-9/16" pieces of Porch Molding (5-70) to fit at the front edge of the porch floor (see illustration). If desired, miter the outside ends at 30° to fit against the tower and bay walls. Glue them into position, slots up and flush to the front edge of the floor.

2. Lay the large Porch Decor piece (1/8" plywood) face down on your work surface, and glue on 9 pieces of 1-1/2" Dowel (6-2) as shown in the illustration. These pieces glue

against the back side of the Porch Decor. Take care to space them evenly and to get them straight.

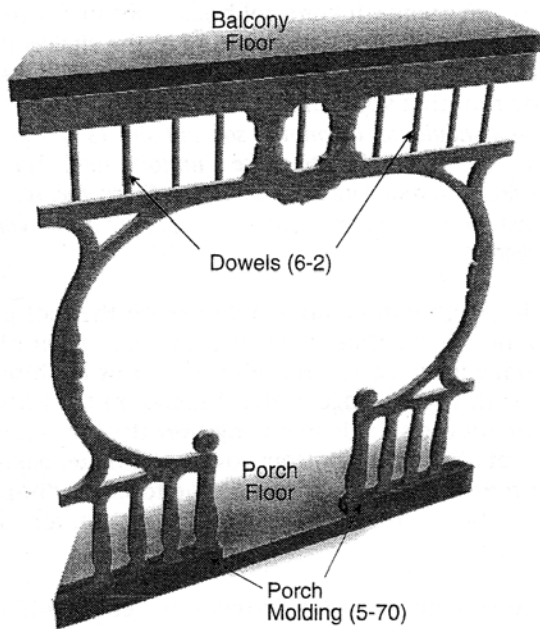

3. Glue the bottom of the Porch Decor piece into the slots of the Porch Molding (5-70) that you positioned in step 1. Run a bead of glue along the top edge of the Porch Decor and push it back under the Balcony Floor until it is standing straight. The Balcony Floor should overhang the front surface of the Porch Decor by about 1/8 inch.

Balcony Rail

1. Cut a 10-1/8" piece of Balcony Molding (6-4) to fit between the tower and bay walls on top of the Balcony Floor. It will fit flush to the front edge of the Balcony Floor. If desired, miter the ends at 30° to fit against the tower and bay walls. Glue this piece into position, slot up and flush to the front edge of the Balcony Floor.

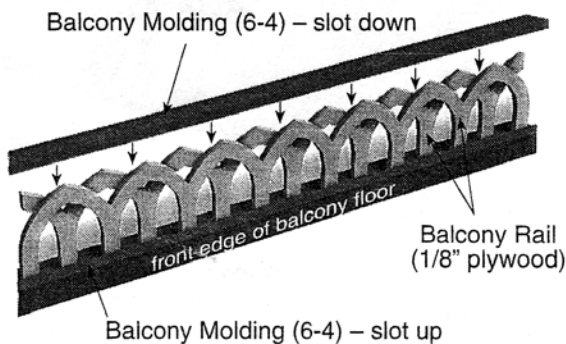

2. Locate the two pieces of Balcony Rail (1/8" plywood). Center the shorter piece against the back of the longer piece with the bottoms flush. Glue them together. Glue this assembly into the slot in the Balcony Molding (6-4).

3. Cut a piece of Balcony Molding (6-4) to fit on top of the Balcony Rail assembly. This piece will butt against the second story window sills on both sides. Measure carefully before cutting. It is best to cut slightly long at first and then sand or trim to fit.

Inside Stairs

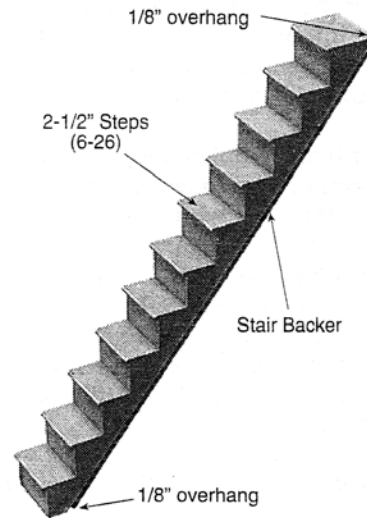

1. Locate 13 Stairs (6-26) and a Stair Backer (1/8" plywood). Using the illustration as a guide, begin at the bottom of the Stair Backer and glue each stair in position until you reach the top. Notice that the first step and last step are approximately 1/8" off the ends of the backer. This makes it possible for these two steps to fit flush against the first floor and second

floor without the backer interfering. Notice: This illustration shows only 11 steps – the San Franciscan Kit (SF557) actually uses 13 steps.

2. When the glue from step one is dry, glue the stairway in place with the top step inside the stairwell hole and flush with the top of the second floor. See box photo for positioning. Paint before gluing.

3. Measure and cut pieces of Universal Trim (5-3) to cover the interior edges of the stairwell hole.

4. Repeat the entire process for the next stairway.

Foundation Brick

1. Measure the front foundation from the left corner (the corner where SF6 meets SF7). Put a mark on the foundation wall at 6 1/4" from the corner and another mark at 11 1/4" from the corner. These will mark the position of the front steps where it will be best if you do not have any foundation brick or paint. Mask right and left edges of this area with masking tape.

2. Before applying the brick pattern, take a moment to consider what color your mortar lines will be. Some intermediate shade of gray is most natural. Mask off the edges of the first floor so you do not get any paint or brick powder there. Paint the foundation walls. Do not paint between the lines that you drew in step 1.

3. Peel the webbing from the Brick Tape (7-1) as shown.

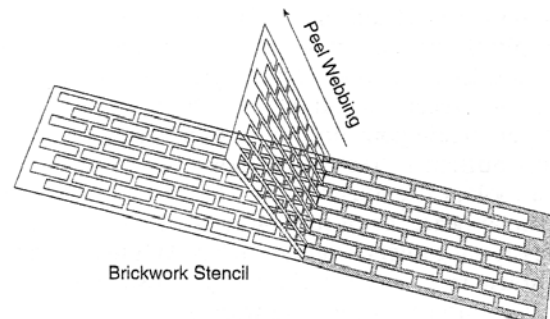

4. Stick the stencil to the foundation wall leaving enough overhang at the corner to hold onto for removal. Press firmly for full contact – otherwise, you may have brick material seeping under the template into the mortar area. We suggest doing only one side at a time.

5. To cover one foot of brick template tape it takes one ounce or 1-1/4 tablespoons of brick powder. Put about 3 tablespoons of tacky glue (or other white glue) into a cup, add an equal amount of water to the glue. Mix well. Put the appropriate amount of brick powder for the length of surface you are going to brick into a different cup. Slowly add small amounts of glue mixture to the brick powder (It is easy to add too much glue mixture, so proceed with caution). Mix after each addition. Continue until mixture starts to hold its own shape like cake frosting.

6. Spread brick mix over the webbing with a putty knife to about 1/16"–1/8" thick.

7. Remove webbing within 5 minutes. Stick the overhanging webbing to a piece of scrap wood and pull as you did when taking the webbing off of the backing. The wood handle will help pull the webbing off evenly.

8. If needed, touch up the bricks with a small piece of wood while the bricks are still soft. Wait for bricks to dry on one surface before proceeding to the next.

Even more important, the spaces between shakes are arranged so that no space lines up with a space in the row below it.

If you approach your dollhouse roof in the manner shown, you will make the best use of the shakes that Dura-Craft, Inc. has supplied for you, and you will have a dollhouse roof that you can be proud of.

You should not attempt to sort out shakes of a particular size or color in an effort to make a uniform roof. You will lose the wonderful authenticity of the Dura-Craft, Inc. roofing method, and you will run out of shakes long before your roof is complete.

1. Remember those lines you drew on the roof parts? Well, now is the time to put them to use. Beginning at the bottom edge of each piece, glue a full row of shingles (5-150) with the top edge of the shingles on the line. The bottom of the shingle will hang over the bottom edge of the roof. When the bottom row is complete, begin the next row and work your way to the top. See "important" information at the beginning of this section for the best approach.

2. At straight roof edges, overlap the edge with the shingles. When the glue is very dry, you can easily trim the shingles flush with the roof edge.

In valleys and where roof edges are angled, you must cut shingles to fit the angle before gluing.

When you have completed the main roof pieces, do the tower roof.

Porch Steps

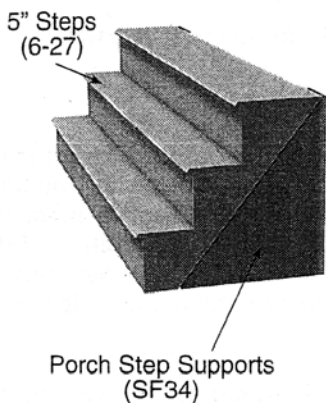

1. Locate the 3 Porch Steps (6-27) and the Porch Step Supports SF34 (MDF). Glue this assembly as shown, making sure that the bottom edge of SF34 measures 1-7/8 inches. Then glue the assembly to the foundation in front of the front door. See box photo.

Pencil Lines 7/8" apart

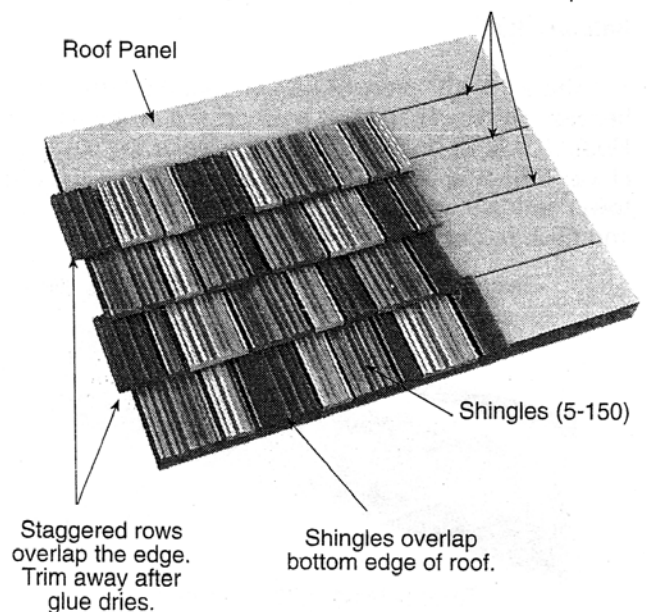

Roof Shingles (Shakes)

IMPORTANT: Building a perfect shake roof requires an understanding of the methods used by roofers in the real world. Shakes are not uniform in width or color, so you need to apply them with these natural variables in mind. At Dura-Craft, Inc., we have gone to great trouble to ensure that you receive a suitable variety of widths and colors. If you create your dollhouse roof with care, it will have a truly authentic, real world look.

Take a look at the illustration. The first thing you will notice is the appearance of randomness. This is exactly how professional roofers arrange shakes. While making your dollhouse roof, you should keep a constant eye toward mixing up the colors and widths.

Placing the Tower Roof

1. Glue six pieces of Tower Cap Molding (5-163) around the top of the tower. The top of the molding should be flush with the top of the tower walls. The thick side of the molding should be up.

2. Glue the tower roof to the top of the tower. View it

from all directions to ensure that it is straight.

5. Glue the Finial (5-94) into the tower roof.

Final Trim

1. Using the box photo as a guide, cut and position trim pieces on roof edges. Pieces can be cut from fascia trim (5-158). When fascia trim is in position, glue the Gable Trim (1/8" plywood) pieces in position on each of the two gables. Gable Decor (1/8" plywood, Sheet SFC) can now be glued to the Gable Trim (see box photo).
2. Measure and cut molding (5-154) to fit on the exposed front edges of the third floor between the tower and bay walls, and also on the front edge of the Third Floor Extension Right.
3. Position the Side Wall Decor (1/8" plywood, Sheet SFB) at the top edge of the two side walls, under the eaves.
4. Again, using the box photo as a guide, glue on the Large Gussets (5-141) under the window sills and on the Side Wall Decor.
5. We have included a little bit of extra molding in the kit for those of you who want to add things that we didn't think of. You may wish to customize your house and add features you specifically want. We encourage innovation.

Congratulations! Enjoy.

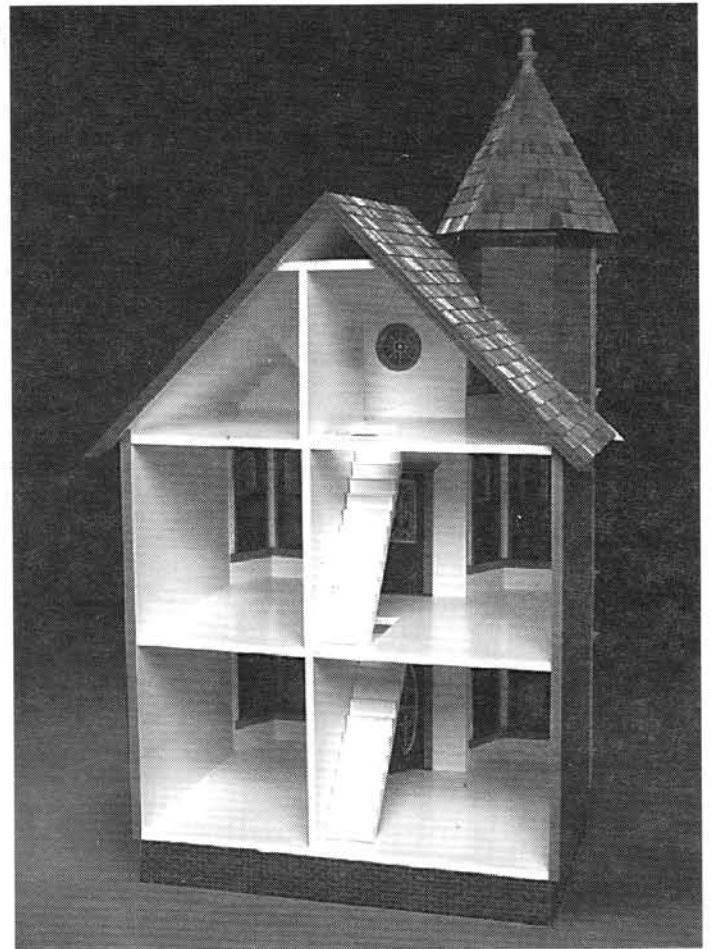

1/8" Plywood Pieces

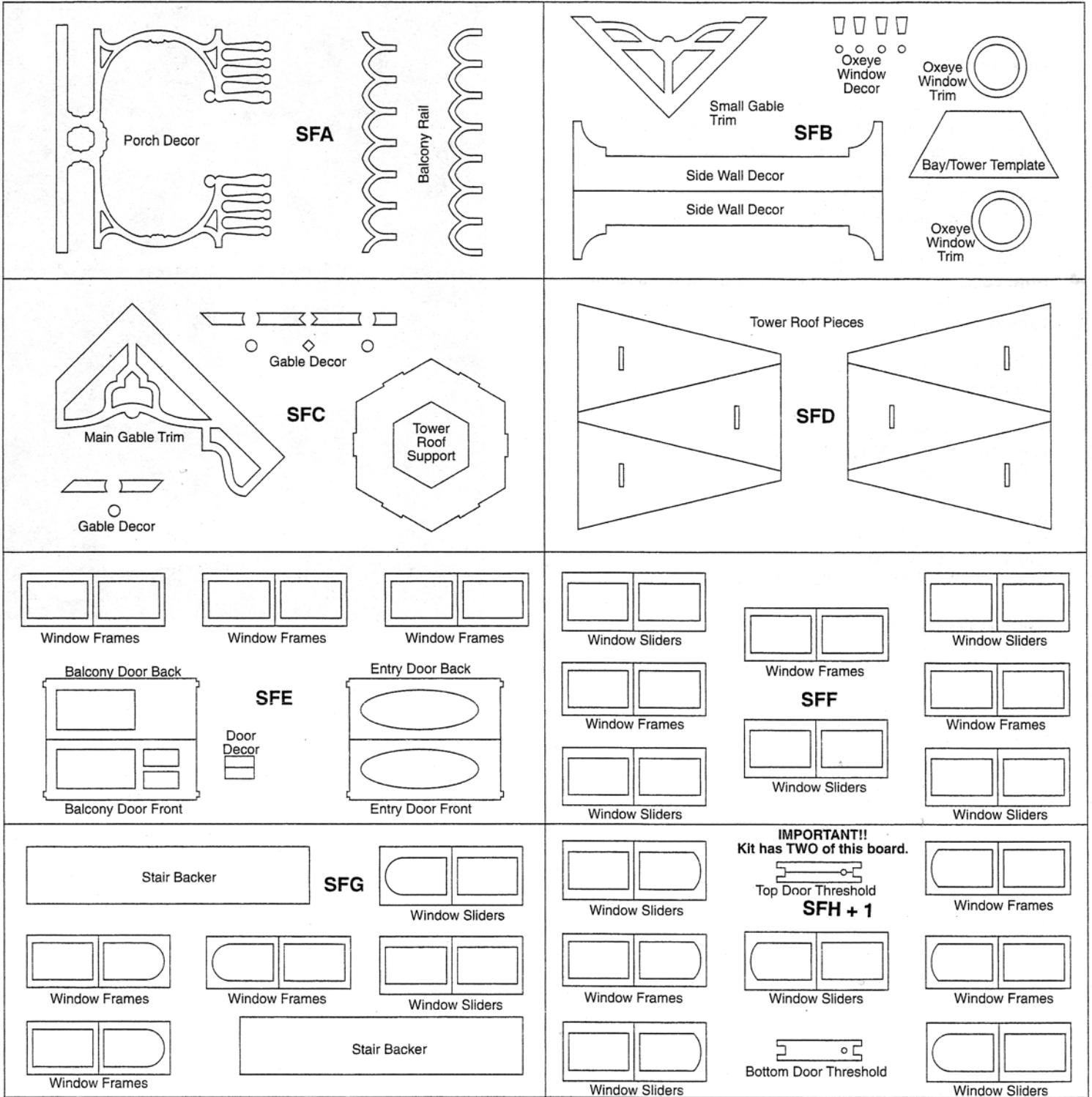

Medium Density Fiberboard (MDF) Pieces

IMPORTANT: Dados & Rabbets (notches) are on the back and are indicated by dotted lines.

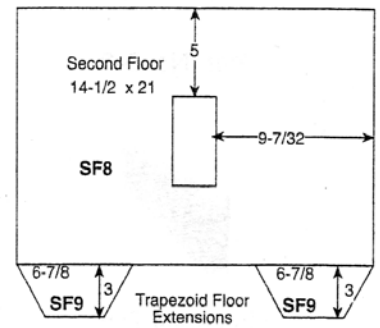
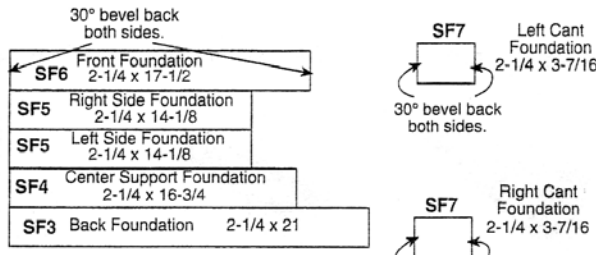
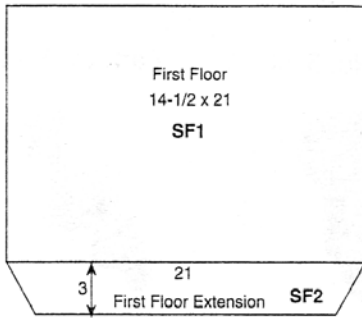

= SIDING

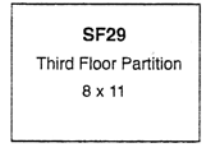
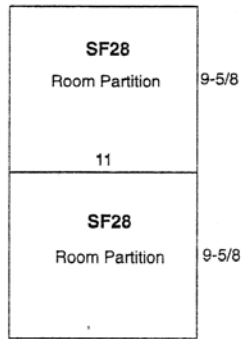
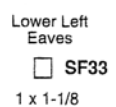
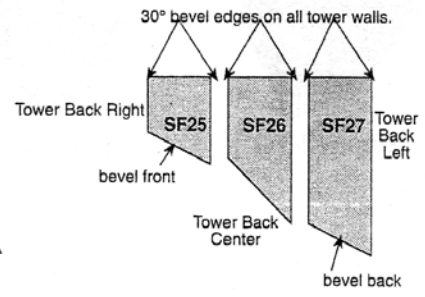
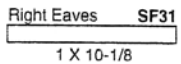
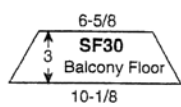
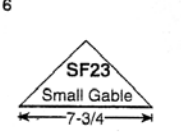
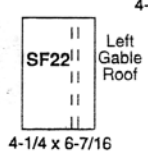
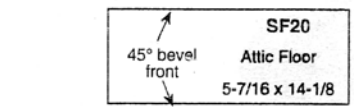
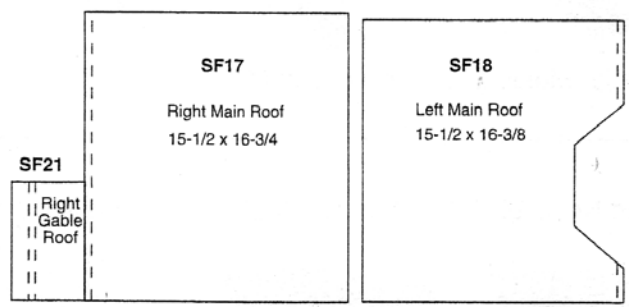
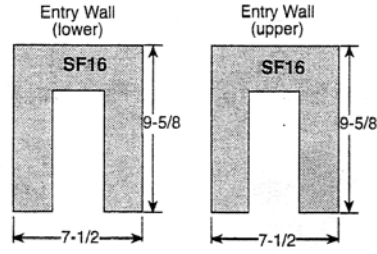
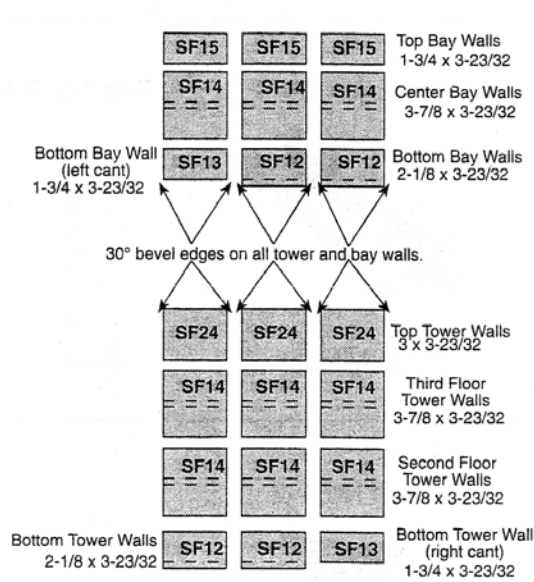
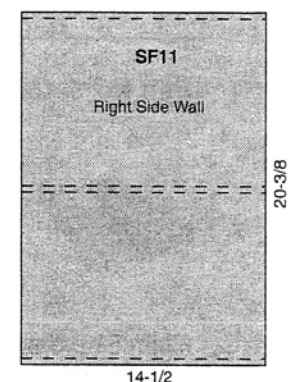
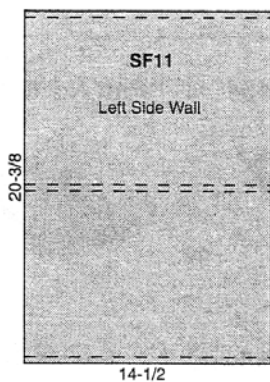
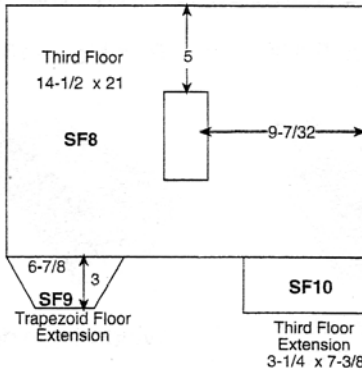

Part No. 5-3



Universal Trim

Part No. 5-8

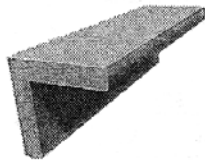

Corner Molding

Part No. 5-70



Porch Rail Bottom

Part No. 5-141



Large Gusset

Part No. 5-94

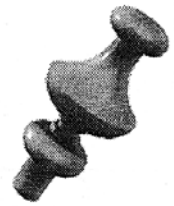

Finial

Part No. 5-150



Plain Shakes
(Shingles)

Part No. 5-154



Cornice/Sill Molding

Part No. 5-158



Fascia Trim

Part No. 5-160

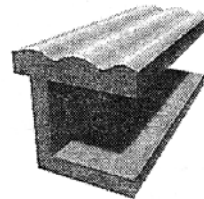

Door/Window
Molding

Part No. 5-161

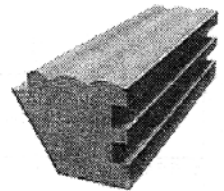

Window Molding

Part No. 5-162

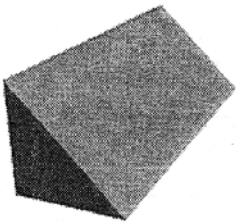

Triangular Molding

Part No. 5-163



Tower Cap Molding

Part No. 6-2



Dowel

Part No. 6-4

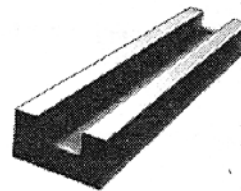

Balcony Molding

Part No. 6-17



Door Knob

Part No. 6-26

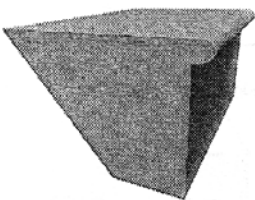

Steps (2-1/2'')

Part No. 6-27

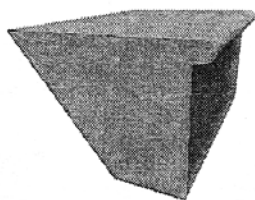

Steps (5'')

Part No. 7-1

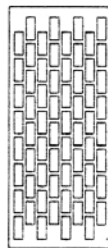

Brick Tape

Part No. 7-2



Brick Mix