

78#

Dry fit each piece before gluing. This will ensure that you have the right piece for the right place and that you will make sensible judgments about where to put the glue.

Replacement parts. Dura-Craft, Inc. has gone to great lengths to grade and sort pieces for quality and workmanship. We think you will be pleased. However, if you discover a faulty, missing, or damaged part, Dura-Craft, Inc. will quickly replace it, even if the damage is caused by improper assembly. We have included a "Missing and Broken Parts Replacement Form" to assist you.

Drawings. The progressive construction pictures in this instruction booklet are *not* photographs. They are 3D drawings constructed piece by piece on a computer. As a matter of convenience, some of the detail has been deliberately left out of the drawings. This won't be a problem if you keep in mind that the drawings are designed to give you the "big picture" and should not be subjected to undo analysis. We are of the opinion that you can keep track of little things like making sure that the siding is on the *outside* of the house.

Painting. You should keep in mind that these instructions are designed to help you construct the basic house kit. If it is your intention to paint, wall paper, etc., you will need to make your own reasonable judgments about when these procedures will best be performed. Remember that we don't know whether you are going to use electrical wiring under your wallpaper (for example).

However, as a general rule, if you are not electrifying your doll house, it is much easier to paint and/or wallpaper as you go along. Because glue holds best when paint is not involved, we have found it best to build the basic shell of the house before starting to paint.

Best results can be obtained by using a good sealer before applying paint. Latex paint is preferred.

OK, let's get started!

IMPORTANT! *First, familiarize yourself with the pages of parts at the end of these instructions. If you know how to identify parts before you begin, you will save a lot of time and this will be a much more pleasant building experience.*

If you have the space and patience to do so, lay out the MDF (Medium Density Fiberboard) pieces in the exact order shown in the parts list. This will make it very easy to locate parts as you proceed.

Floors

1. Locate the four first floor pieces - MR1, MR2, MR3, and MR4. These pieces are made of MDF (medium density fiberboard) which is the same on both sides. Consequently, you don't have to worry about which side is up if the piece is symmetrical. When we have pieces that are asymmetrical, we will be sure to let you know which side is which.

2. Edge glue the First Floor Extension (MR2) to the left edge of the First Floor (MR1). It should be flush to the back edge.

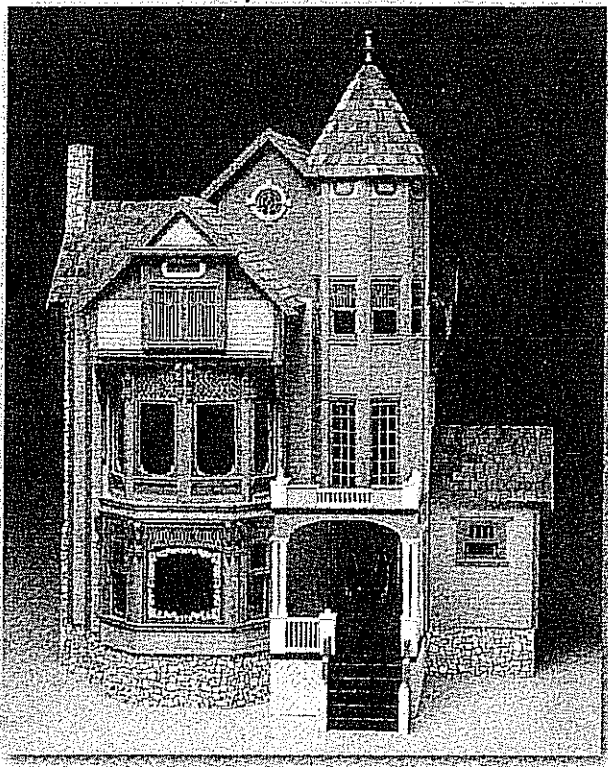

MR625 Marquam Hill Mansion Assembly Instructions

© 1999 Dura-Craft, Inc.

Building a doll house is fun! How long it takes you to build the Marquam Hill Mansion will depend on who you are and what a "finished" doll house means to you. If you are simply looking for an unpainted structure that your child can enjoy, this kit will go together fast. However, if you want a show piece with paint, wallpaper, electric lights, etc., that will lengthen the assembly process. Some of you will blast through this project in short order, but the rest of us will enjoy dawdling along and admiring our work as we go.

Save the box. The picture will be a good reference for what your kit should look like. You will note, though, that some small adjustments have been made since the box photo was taken. These are the result of improvements made after the prototype models were constructed. We will try to keep you informed of any changes as we go.

Don't get ahead. The order of events is important.

Release the parts gently. Parts in the 1/8 inch plywood boards must be removed by exerting gentle pressure. A few will require that you cut them loose with your knife. Cut from the front side of the board (the side with the most visible cut marks) and please be careful.

Glue. Everyone has a favorite kind of glue. Most glues work fine if they are recommended for woodworking or porous materials. We recommend a yellow woodworking glue.

3. Edge glue the First Floor Bay (MR3) to the front edge of the First Floor (MR1). The positioning of this piece is critical. The left edge of MR3 must be exactly 2 inches from the left edge of MR1.

4. Edge glue the Kitchen Floor (MR4) to the right edge of the First Floor (MR1). It should be flush to the back edge. Hereafter this group will be called First Floor Assembly.

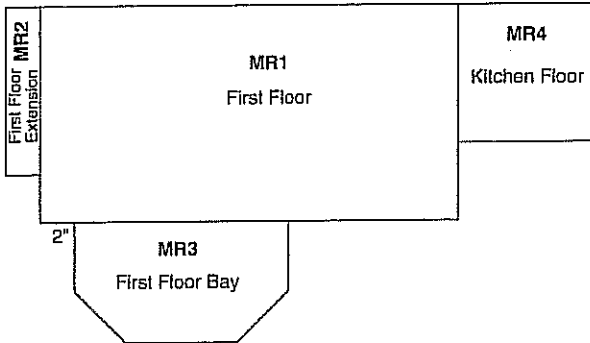

4. In exactly the same manner, create the Second Floor Assembly and Third Floor Assembly. They will not have the kitchen floor extension on the right side. Set them aside for later use.

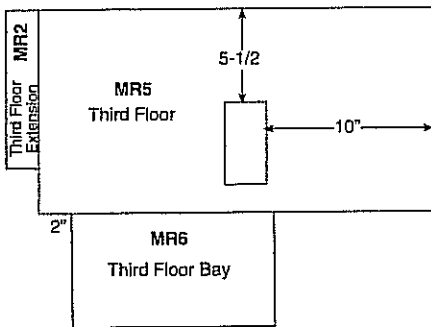
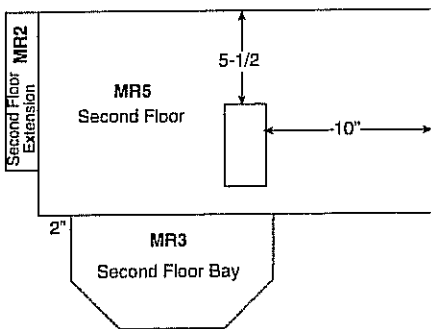

Foundation

1. Locate the fifteen Foundation pieces – MR7-19 (there are 2 pieces of MR7 and MR10). First, turn the First Floor Assembly on its top with the bay toward you and the extension to your right (see drawing).

TIP: Some pieces may look a lot like other pieces. It is a good idea to measure each piece and compare it to the parts list in order that you not glue the wrong piece in the right spot.

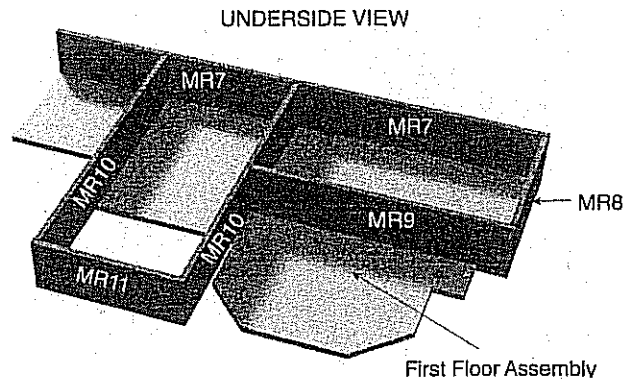

2. Glue the first seven pieces (MR7-MR11) to the First Floor Assembly in numerical order as shown. Be sure to align the edges of the foundation pieces with the edges of the floor where appropriate.

TIP: A good carpenter rarely relies on gravity or friction to produce a suitable bond between pieces. To force a tight fit while glue dries, use clamps, tape, or brads. Because it is quick and easy, we prefer masking tape.

3. Glue the remaining eight foundation pieces (MR12 – MR19) to the First Floor Assembly in numerical order as shown. Again, be sure to align the edges of the foundation pieces with the edges of the floor.

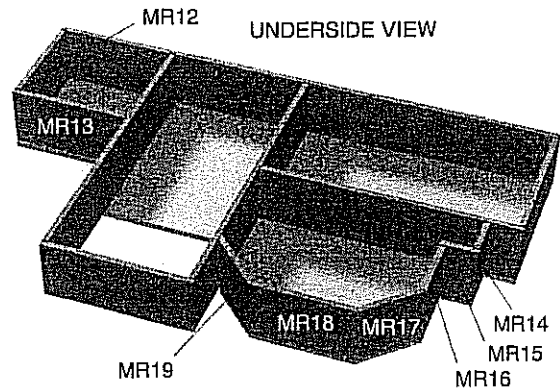

4. Return this assembly to its upright position as shown in the following illustration.

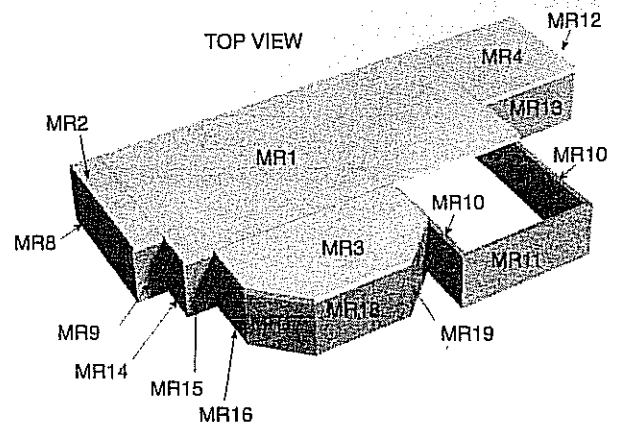

TIP: This entire building can be put together in a hurry if you use glue and tape strategically, allowing the tape to do the work until the glue dries. However, there are some advantages to allowing the glue to dry before proceeding to the next step (except where indicated otherwise.) We recommend the "let it dry method" unless you have a deadline.

Walls & Floors

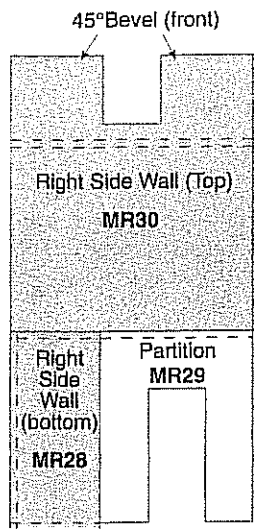

1. Locate the Right Side Wall Top (MR30), the Right Side Wall Bottom (MR28), and the Kitchen Partition (MR29). Edge glue these three pieces together as shown. Remember that the Kitchen Partition is inside the house while the Right Side Walls are exterior walls. This will affect the way you choose to paint or decorate.

2. Find the Left Side Wall (MR20) and Right Side Wall Assembly (from paragraph 1). Glue the Second Floor and Third Floor Assemblies into the rabbets (notches) that run across the center of the two walls. The back edge of the Second Floor

Assembly should be flush with the back edge of the two walls (The front edge will not be flush.) This operation can be frustrating if you don't spend a minute thinking about it first. **TIP:** Stand the second floor assembly and the Left Side Wall on their back edges. Glue and tape. Add the Right Side Wall Assembly. Glue and tape. Slide in the Third Floor Assembly. Glue, tape, and check for squareness. Allow to dry. See the illustration for proper orientation of parts.

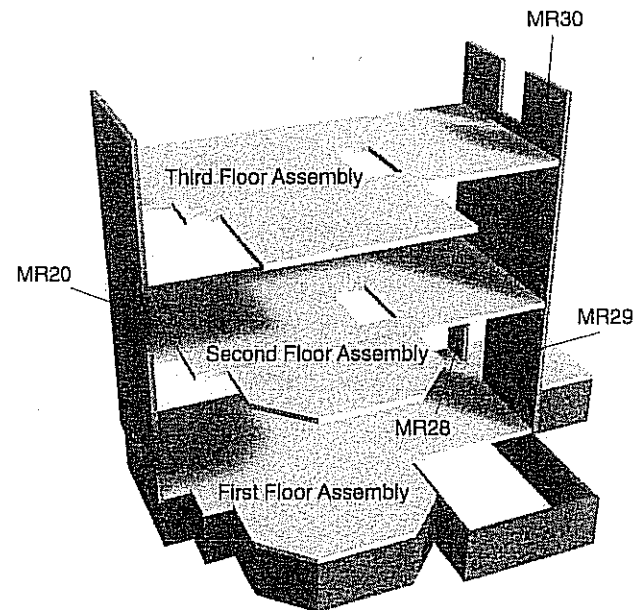

Important Notice: Please take a minute to study the direction of the siding on the outside of the walls. Up-side-down siding will not impress your friends.

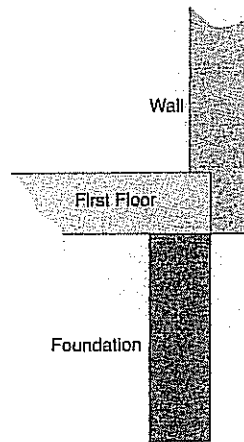

2. Glue the assembly to the first floor (flush at the back) and secure it in position.

The rabbets (notches) at the bottom of the walls fit onto the floor in such a manner that the bottom of the wall covers the edge of the floor. (The Kitchen Partition MR29 sets on top of the floor.)

3. View your work from every angle to ensure that everything is square, that walls are vertical, and that the floors are properly seated in the rabbets. Secure the assembly with tape and wait for the glue to dry.

4. Locate and position the following walls *in this exact sequence*: MR21–MR27, MR44, and then MR39–MR43. Use the illustration to find the proper position for each piece. Notice that the right edge of MR44 *does not* line up with the right edge of MR26.

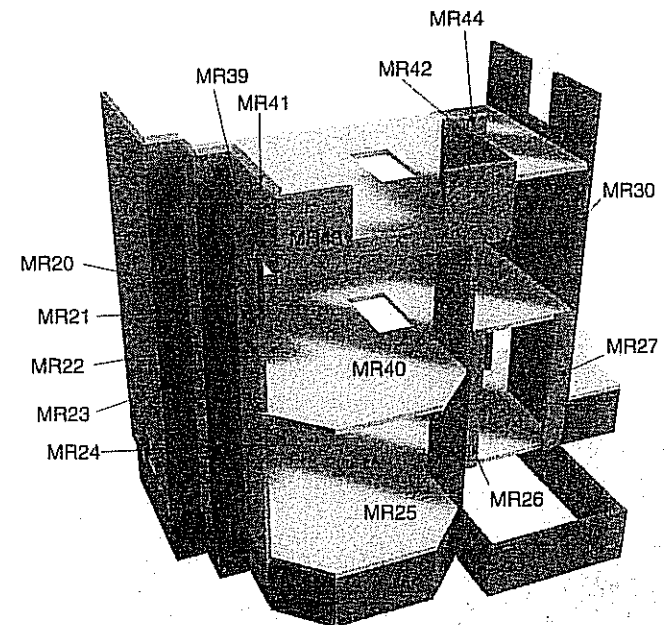

5. Locate the Bottom Bay Walls – MR31(2), MR32 and the Center Bay Walls – MR33(2), MR34. Position as shown. Make every effort to get a good fit where the pieces meet at the front corners. The bottom bay walls *stand up* from the first floor. The center bay walls *hang down* from the second floor.

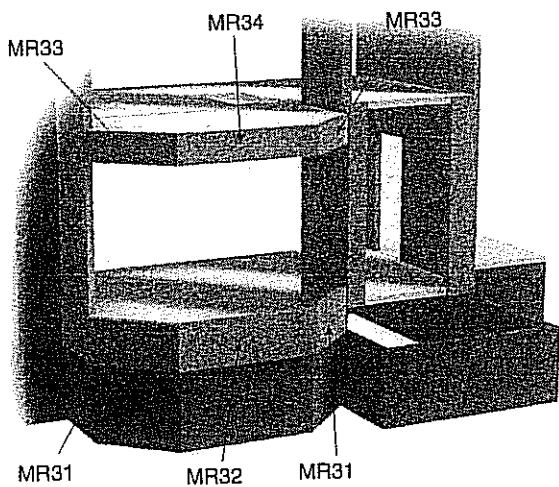

6. Now is the time to make sure everything is properly oriented, that the walls are vertical, that the floors are flush to the back of the walls, and that everything is square and properly secured. If the glue dries while anything is out of position, difficulties will follow.

7. Locate some Angled Molding (5-165) and cut six 6-7/8 inch lengths. Glue two of the lengths together at the angled edges. Do this again. You should now have four pieces like this:

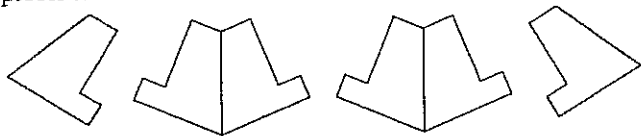

8. Locate the four Bay Mullions (MR35). Glue the Angled Moldings and the Bay Mullions to the center and bottom bay walls in the following manner:

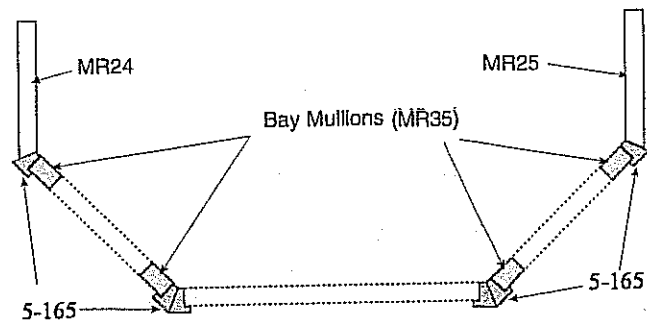
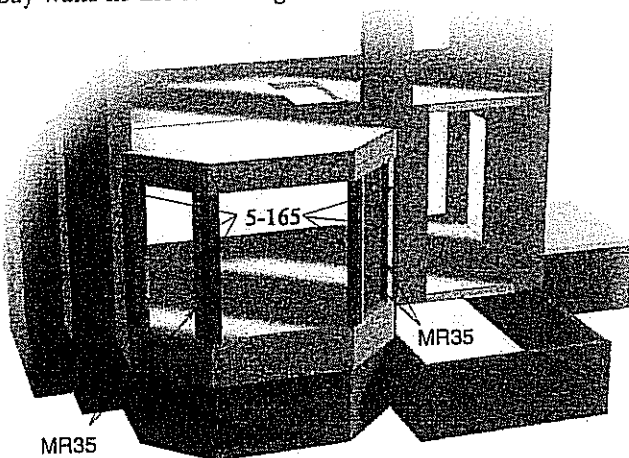

Notice that the Bay Mullions (MR35) are flush to the walls. The Angled Moldings (5-165) sit forward so that their front edges are in front of the walls and back edges are flush to the inside of the walls.

9. Locate the Front Door Thresholds – MR36 (2). One piece will be glued horizontally in the doorway, against the front edge of the first floor. It will fill the gap between the floor and the porch floor which will be installed next. The other MR36 glues against the front edge of the second floor where it will fill the gap between the floor and the balcony floor which will be installed later.

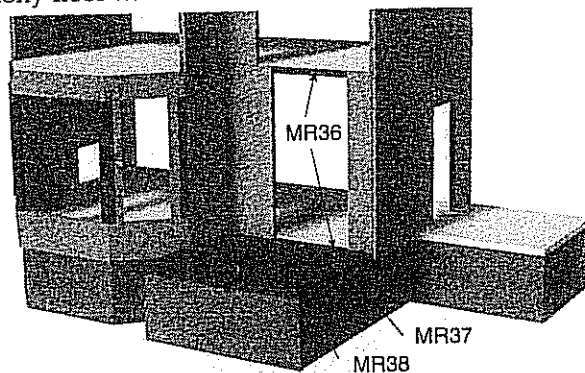

10. Locate the two Porch Floor pieces (MR37 and MR38). Edge glue the two pieces together (flush on the right side) and then glue them to the top of the foundation walls as shown. The Porch Floor will overlap the foundation walls by about 1/8" on the three exposed sides.

Gables

1. Locate the Outside Left Gable (MR47) and glue it to the top of the Left Side Wall (MR20). The tips of the gable will hang over the edges of the wall. Make sure that the gable is centered on the wall.
2. Locate the Inside Left Gable (MR48) and glue it on top of the wall (MR22) with the front tip hanging off the front edge of the wall by 3/16 inch.

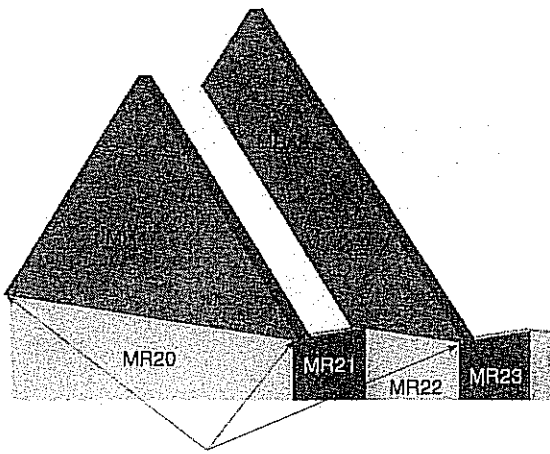

3/16" overhang

Tip: While gluing gables, ensure they are exactly vertical and that they are secured in such a manner that they remain vertical while the glue dries.

3. Locate the Main Gable (MR49) and glue it to the top of the Top Entry Wall (MR44). The right edge of the gable is *flush* with the right edge of the wall.

4. Install the Front Gable (MR50) on top of the Top Bay Wall (MR43). The window openings should line up. When properly aligned, the gable tips will overhang the wall by approximately 3/16" on both sides.

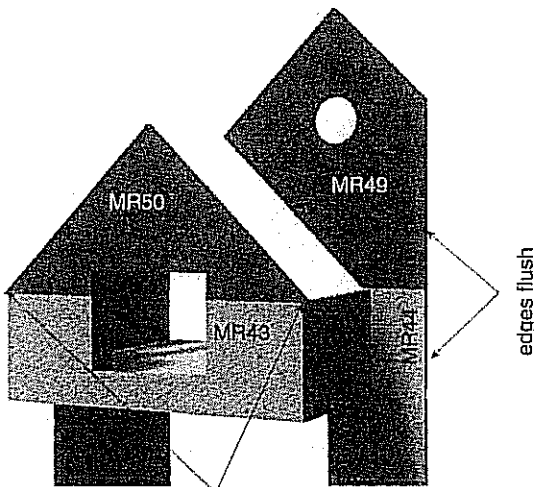

3/16" overhang

D. Roof Pieces

1. First, locate the pieces in the following diagram. Edge glue them together as shown. Allow to dry.

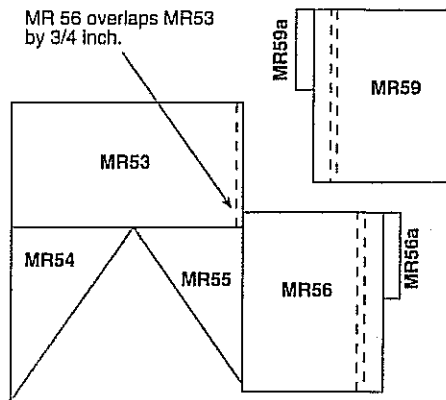

2. You will need to mark the roof pieces with pencil lines so you can properly position the shingles when you have your house completed. Start at the bottom edge of each roof piece and measure up 7/8 inch at both the right and left edges. Using a straight edge, mark a horizontal pencil line all the way across the piece. Then repeat the process every 7/8 inch until you reach the top of the piece.

The illustration shows the proper orientation for each roof piece. After marking, set MR78 & MR78a aside. We will use them later.

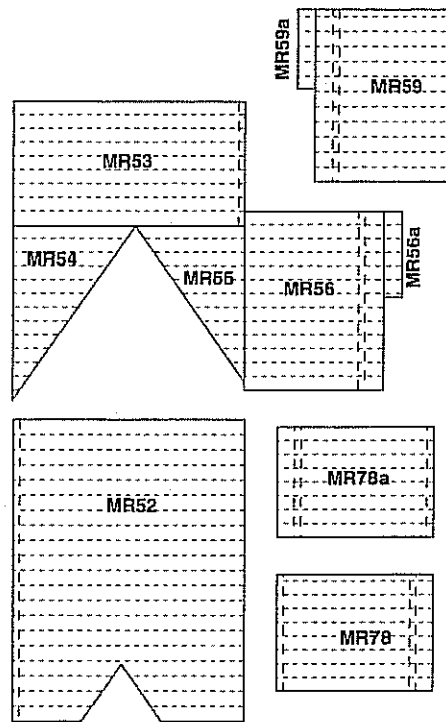

3. Glue the Left Main Roof assembly to the Right Main Roof (MR52). The top edge of the Left Main Roof assembly glues to the underside of the Right Main Roof. This is most easily accomplished if the Right Main Roof (MR52) is face down on your work surface so the Left Main Roof assembly can be stood vertically.

It is very important that these two assemblies form a

90° angle. Use a square or a piece of typing paper to ensure that the two roofs are at the proper angle. Tape securely until dry.

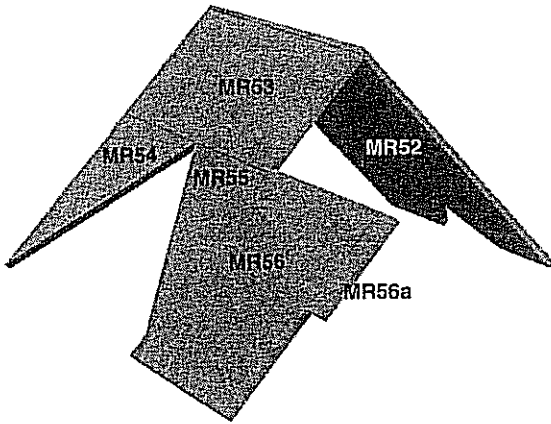

4. When the glue is dry, glue the Main Roof assembly on the house using the Main Gable and Front Gable as position references. The Front Roof Left (MR56) will overhang the peak of the Front Gable (MR50) by exactly 1/4 inch. It is a good idea to dry fit the roof before gluing.

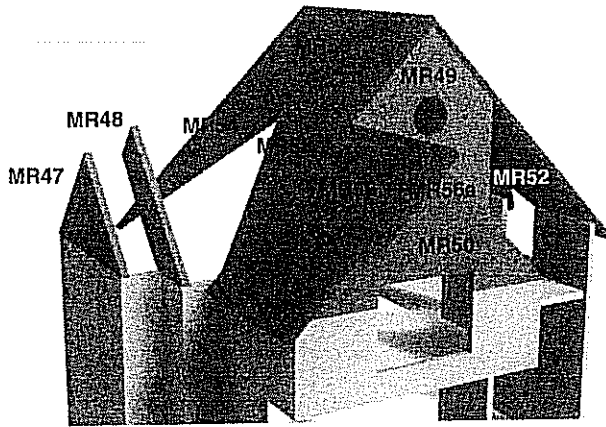

Tip: Because of the weight of the roof, it may want to sag at the back. To avoid this, cut a piece of 3/8" x 3/8" molding (5-5) approximately 15-3/4" long. Place the top end under the back edge of the roof at the peak, and place the bottom end on the third floor. Slide the bottom toward vertical until the top of the roof is level. When you have completed this, double check to make sure that the roof dados are properly seated on the gables, then tape securely.

5. While the glue is still wet, glue the Front Roof Right assembly (MR59 & MR59a) to the right side of the Front Gable (MR50). Also glue it to the underside of the Front Roof Left assembly, and to the Main Gable (MR49). Tape securely, and allow the glue to dry.

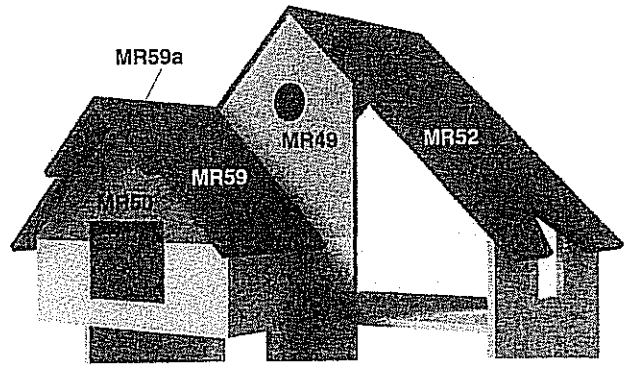

6. Locate the Front Extension Bottom (MR57) and the Front Extension Gable (MR58). Lay the Front Extension Bottom on your work surface with the bevels up. Glue the Front Extension Gable on top of the Front Extension Bottom as shown. The Gable should be back 3/8" from the front edge of the bottom piece.

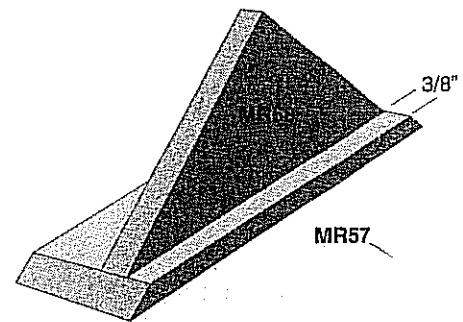

7. Glue this assembly up into the front roof group so that the back edge of the Front Extension Bottom (MR57) glues against the Front Gable (MR50), and the top edges of the Front Extension Gable (MR58) glue against the underside of the Front Roof Projections (MR56a and MR59a). See the second illustration under the heading Front Oriels on the following pages.

6. Locate the 4 pieces of roof that fit the left side of the house – Back Roof (MR60), Back Roof Extension (MR61), Front Roof (MR62), and Left Front Roof (MR63). Edge glue the Back Roof Extension (MR61) to the back roof (MR60) with the bottom edges flush. Be sure to get the extension right side up – one inch from outside edge of dado to outside edge of Back Roof Extension (MR61).

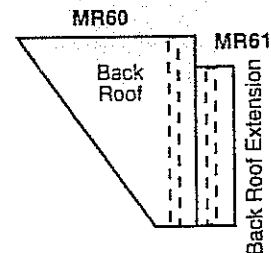

7. As before, put pencil lines on each piece to indicate the position for applying shingles later.

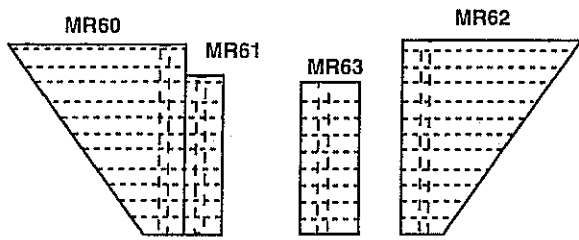

8. Glue the Back Roof Assembly (MR60 & MR61) to the back edges of the Inside and Outside Left Gables (MR47 & MR48). Where the Back Roof assembly fits the Outside Left Gable (MR47), it will overhang the peak of the gable by 1/4 inch. Glue the Back Roof (MR60) to the main roof to give the entire roof assembly stability.

Tip: "Right" and "Left" are always as viewed from the *front* of the house. It is easy to get confused while looking at the back of the house. Sometimes it helps to put "right" and "left" sticky notes on the back of the house to keep yourself properly oriented.

9. Glue the Front Roof (MR62) to the front edge of the Inside Left Gable (MR48) and the top edge of the Back Roof (MR60). Also glue it securely against the main roof.

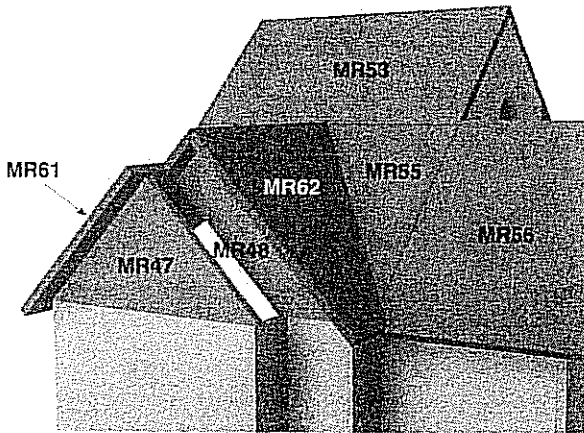

10. Again, while the glue is still wet, position the Left Front Roof (MR63).

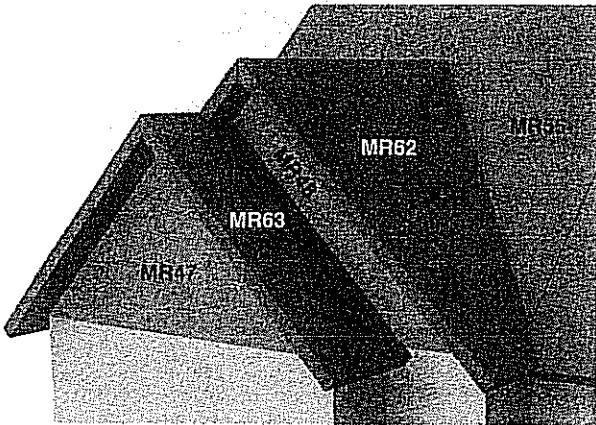

11. Now make sure that all parts and pieces are properly aligned, seated correctly, square, and snugly taped or clamped into position. Wait for glue to dry before proceeding.

Reminder: The box photos can be very helpful. Don't forget to refer to them whenever you are uncertain.

Front Oriel

An oriel is a suspended bay window supported by brackets, corbels, or some similar structure rather than being supported by a foundation or wall. This house has two oriels which we will call the front oriel and the side oriel.

1. First locate the 5 pieces of the front oriel. Glue them together as shown. If properly assembled, the inside edges of MR65 and MR66 will be 4" apart. Tip: This assembly goes together best if assembled face down (illustration is face up).

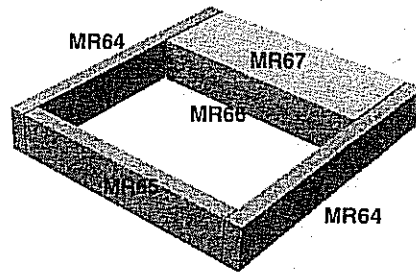

2. Glue the assembly around the window opening in the Top Bay Wall and Front Gable. The top of the assembly should fit up against the Front Extension Bottom (MR57).

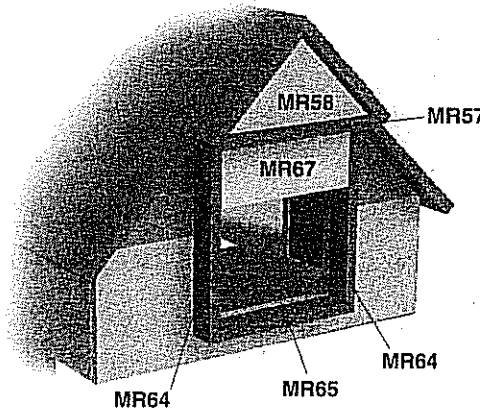

Kitchen

1. Using previously learned techniques, glue the Kitchen Front Wall (MR45) and the Kitchen Side Wall (MR46) to the first floor as shown.

2. Locate the two Kitchen Gables (MR77) and the two kitchen roofs (MR78 & MR78a). Glue the gables into the rabbets and dados in the underside of the roof pieces.

IMPORTANT: The Back Kitchen Roof (MR78a) is 3/8" shorter than the Front Kitchen Roof (MR78). The top edge of the back roof butts up against the underside of the front roof.

3. Glue the roof assembly to the kitchen walls and the right side wall. Make sure that the outside gable sets on top of the Kitchen Side Wall (MR46). Also view from several angles to make sure that the peak of the roof is level.

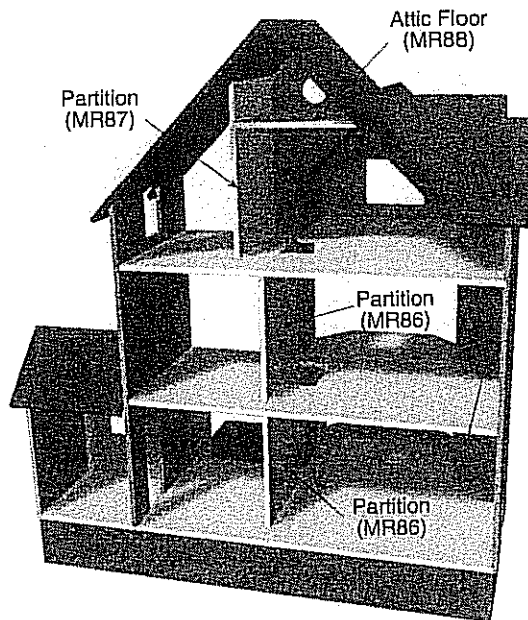
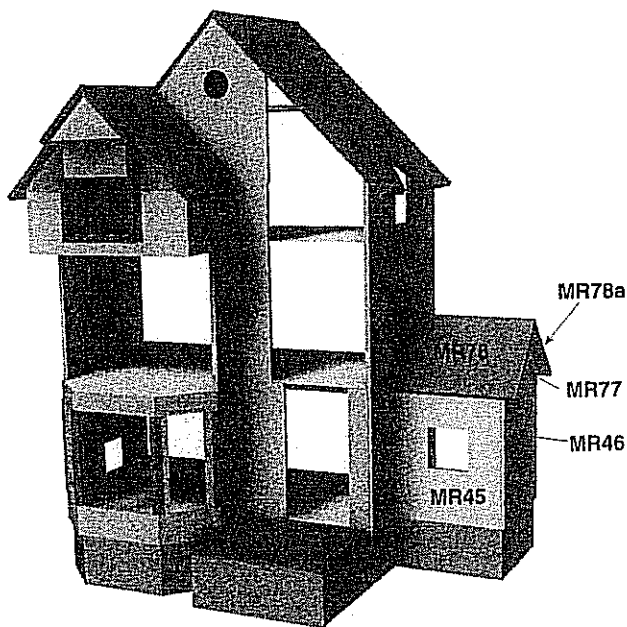

Tip: This completes the primary structure or "shell" of the house. If you intend to paint and haven't already begun, now is a good time to start painting before we begin adding things that you will have to paint around.

Porch Posts

1. Start by creating three pillars.
 - a. To make a pillar, begin at the bottom with a 2 1/2" long piece of 1"x1" molding (5-164). This is the pillar pedestal.

Room Partitions

1. Locate the two Partitions (MR86). Use the box photo as a guide for placement. The first and second floor partitions should be flush with the edge of the stairwell. Take some time to ensure that the partitions are plumb.
2. The Third Floor Partition (MR87) and the Attic Floor (MR88) fit together at the dado in the partition. Place the Third Floor Partition (MR87) on your work surface with the dado (groove) up and the beveled edge toward your left. Glue the flat, nine inch edge of the Attic Floor (MR88) into the dado so that the floor stands vertically and the bevel at the top is also facing toward the left. Use a carpenter's square or a piece of typing paper to make sure that the two pieces are square to each other.
3. After the glue has dried, glue the assembly into the house so that the partition stands vertically and the two bevels fit against the underside of the roof.

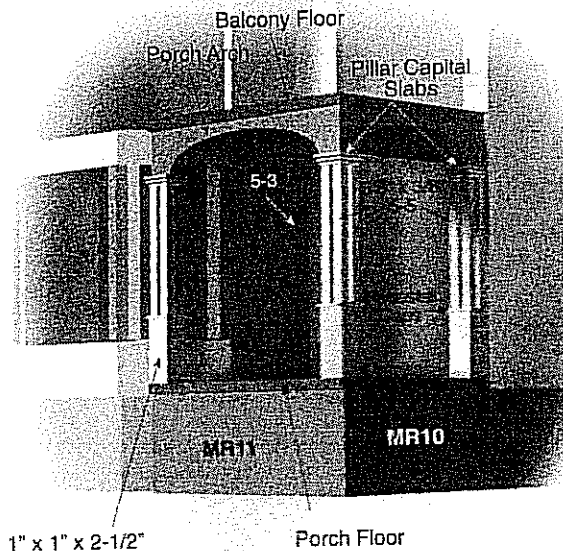

- b. Center and glue a pedestal cap (1/8" plywood - sheet MRG) on top of the pillar pedestal.
 - c. Glue three 3/8"x 3/8" posts (5-5) standing vertically on the pedestal cap. These posts should be set inward approximately 1/16" from the edge of the pedestal cap so that the outside corner of the post is directly above the

outside corner of the pillar pedestal. Each pillar will have an open corner where there is no post.

d. Glue 3 capital slabs (1/8" plywood – sheet MRB) on top of the posts as shown. One each small, medium, and large.

Check to ensure that all posts are properly spaced and exactly vertical.

2. Glue each of the front two pillar pedestals at the outermost corners of the porch floor as shown. The pillar pedestal at the right rear of the porch will be flush to the right edge of the porch floor, and it will stand away from the wall approximately 1/8" (exact position being determined by the uppermost capital slab which glues against the wall).

3. Locate the three porch arch pieces (1/8" plywood – sheet MRJ). Glue the front ends of the right and left arches to the back surface of the front arch. They should be at a right angle. Glue this assembly to the top of the capital slabs on the three pillars. The back edge of the right arch should set against the wall.

4. Locate the two Balcony Floor pieces (MR37 and MR38). Edge glue the two pieces together (flush on the right side) and then glue them to the top of the porch arches as shown. The Balcony Floor will overlap the arches on the three exposed sides.

Tower

1. Lay out the tower pieces as shown in the diagram. Use the measurements in the diagram to create corner posts from corner post molding (5-165)

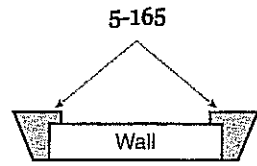

2. Glue a corner post (5-165) to each side of the tower walls as indicated, leaving spaces for doors and windows as appropriate. It is important that you follow the diagram meticulously, and we suggest that you lay

out the pieces exactly as shown. The lip of the corner posts should rest on the front surface of the walls.

3. After the glue has thoroughly dried, tape the tower wall assemblies together with long pieces of masking tape

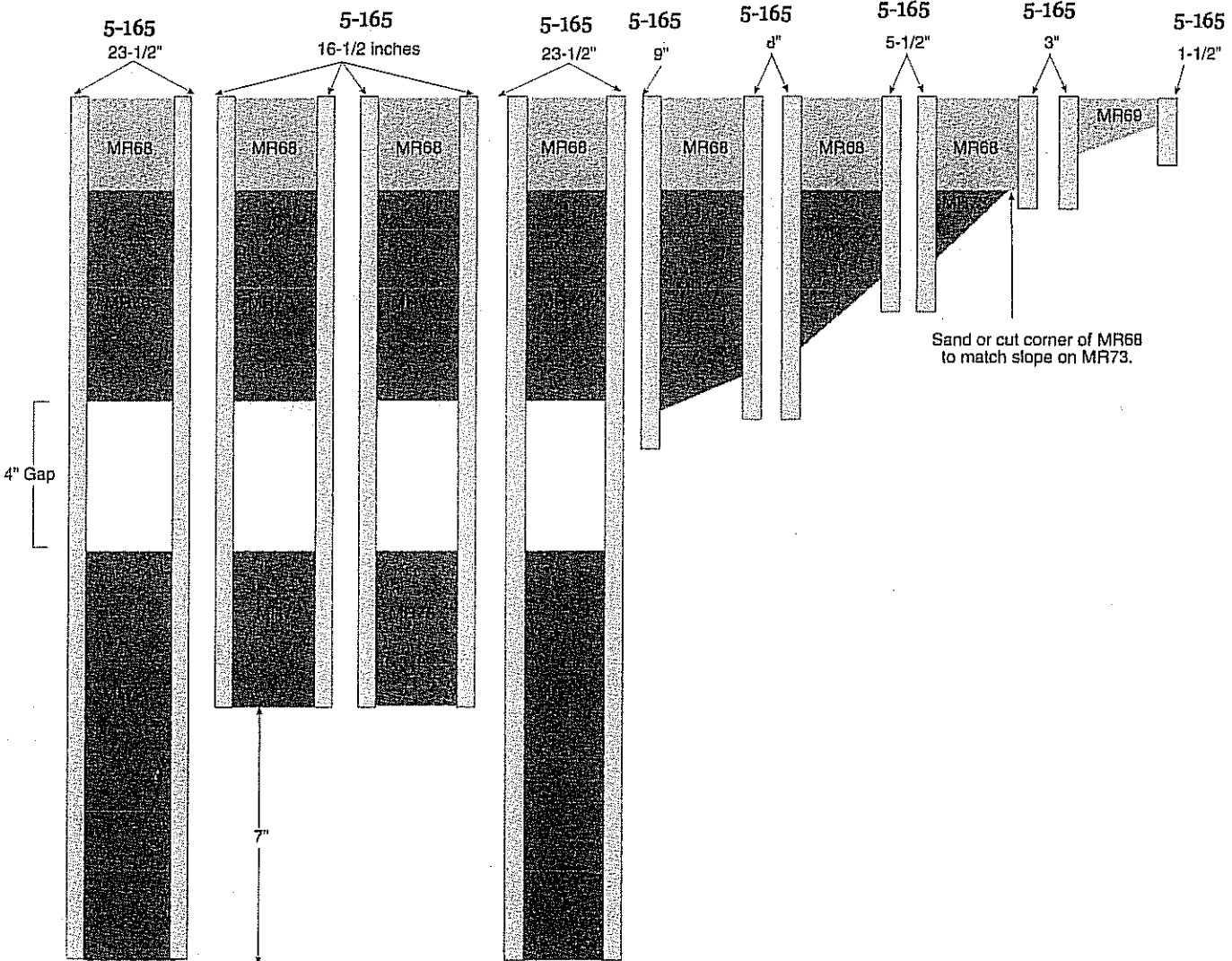

on the corner posts (5-165) The walls should be in the exact sequence shown earlier. Just slide them together, flush at the top, and tape.

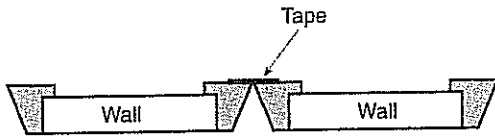

4. Turn the taped assembly over and run a thin bead of glue down each valley between corner posts (5-165)

5. Locate the two octagonal Tower Supports (MR76). Place one support flat on your work surface, run a bead of glue around the eight edges, and then wrap the tower walls around the Tower Support (MR76), top down, as shown. Tape securely. Tape the second Tower Support (MR76) in the area between the door opening and the window openings to maintain the shape of the tower. Do Not Glue this support – it is only temporary and only for the purpose of ensuring that the tower is shaped properly from top to bottom while the glue dries. When the glue has dried, remove the second tower support.

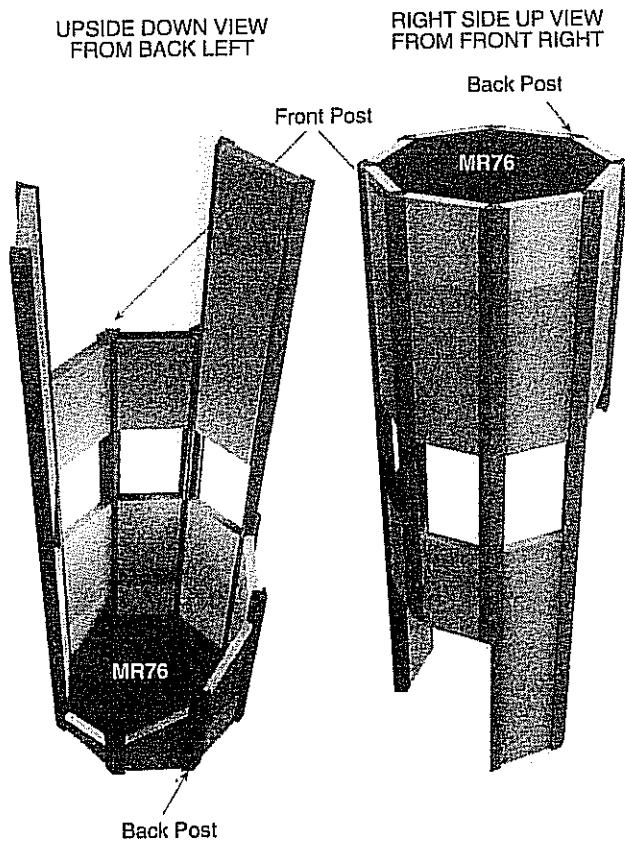

6. Stand the tower assembly upright toward the front of the balcony floor. Orient it so that the front post is facing exactly forward. Push the assembly back until the back post bumps up against the roof. Now move the tower to the right until the rightmost post is overhanging the bal-

cony floor by 3/8".

7. Now, looking from the back of the house, make a pencil mark on the back post that matches the angle of the roof. Cut off the bottom of the post at this mark.

8. Replace the tower on the balcony floor. Position it as before, and push it back. The back post should now fit over the roof so that the next two posts can move up against the roof. Using the same technique, cut off the bottoms of these two posts.

9. Once more, replace the tower on the balcony floor and push it back against the roof. Now the three rear posts of the tower should fit over the roof and the two side posts of the tower should fit back against the wall. Using the same technique, trim off the bottom of the back half of the side posts so the front half will fit back against the wall. The right side post should overhang the edge of the wall by 1/8" – see diagram. (This overhang might seem odd now, but it is important. Later, you will place a 1/8" piece of molding against it, and it will seem exactly right.) The left side post will NOT fit flush to the edge of the wall and you should not try to make it fit – the overlap is intentional.

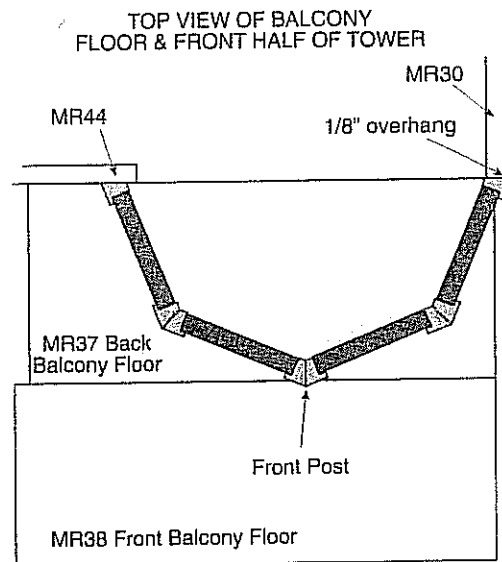

10. When you are certain of the fit, glue the tower assembly to the house. View it from all angles to make sure that it is straight.

Entry Doors

1. Follow the diagram to construct the entry door assembly. Painting will be easiest if accomplished before assembly.

a. Assemble the two entry doors – front, back, glass and decor as shown in the diagram.

i. Punch the scrap pieces out of the Entry Door Fronts and Backs (1/8" plywood, Sheet MRF). Lay the Door Back best side down. Run a *thin* bead of glue around the opening in the Door Back (on the flat surface outside

the hole, not on the inside edge of the hole). Place the appropriate piece of door glass on the Door Back (see box photo to determine which glass goes where).

ii. Run a bead of glue around the back side of the Door Front and center it on top of the glass and Door Back.

iii. Glue on the Door Decor. Weight down or tape until dry.

iv. Lay the door flat on its back and install the door knob (6-17). Push the pin straight into the plywood. See box photo for best position.

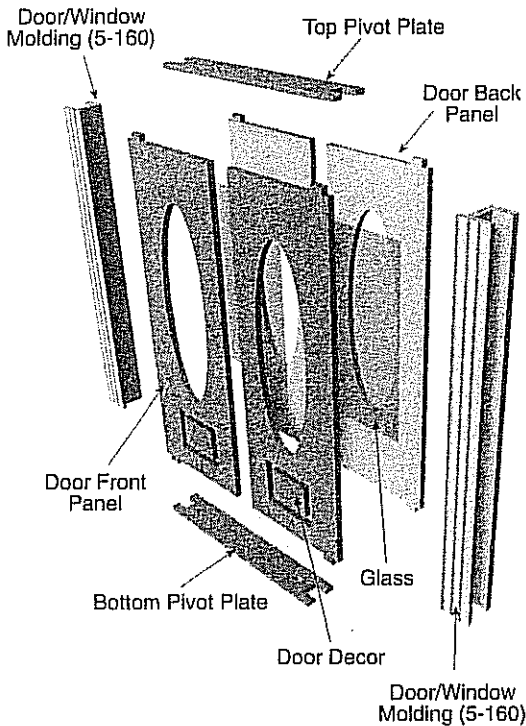

b. Locate an Entry Door pivot plate (1/8" plywood – sheet MRL) and place it into the bottom of the entry doorway with the forked ends straddling the wall on each side. Glue the pivot plate down against the floor, being careful not to get glue in the pivot holes.

c. Cut two 6-3/4" pieces of Door/Window Molding (5-160). Glue these into the sides of the door opening with their bottom ends against the pivot plate. Make sure that they are fully seated against the sides of the door opening and that the decorative side of the molding is on the outside.

NOTICE: Doors will swing best and install easier if the edges of the pivot pins at the top and bottom of the door are sanded or trimmed so that the pins are approximately round. Do this before proceeding.

Also, sand the hinged edge of the door into a rounded shape to give it clearance to swing properly.

TOP VIEW OF DOOR (hinged side)

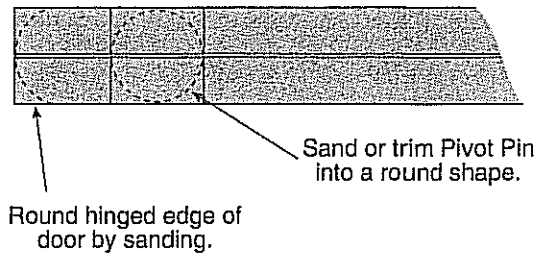

d. Place the bottom pivot pins of the two door assemblies into the holes in the bottom pivot plate. While holding the doors in position, glue the top pivot plate against the top ends of the two door moldings with the top pivot pins fitting into the top pivot plate holes.

e. Cut two 2 5/8" pieces of Door/Window Molding (5-160). Glue these into the sides of the entry opening with their bottom ends against the top pivot plate. Make sure that they are fully seated against the sides of the entry opening and that the decorative side of the molding is on the outside.

f. Cut two 4 3/4" pieces of 3/8 x 3/8 molding (5-5) and glue one on top of the top pivot plate and against the lip of the Door/Window Molding. This piece acts as a spacer between the door and the transom window above. Glue the second piece against the underside of the second floor and against the lips of the Door/Window molding. This piece fills the space between the transom window and the second floor.

g. Finally, assemble the transom window – Transom Window Back, glass, and Transom Window Front. Install it between the two 3/8 x 3/8 molding pieces that you installed in paragraph f. The transom window is designed for a snug fit – you may need to sand edges. Numerals should read correctly from the outside of the house.

Tower Doors

TOP VIEW OF BALCONY FLOOR & FRONT HALF OF TOWER

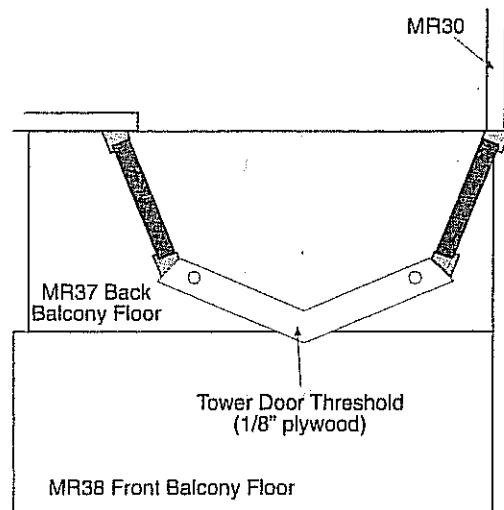

1. Locate the two Tower Door Thresholds (1/8" plywood

- sheet MRO). Glue one of them on the balcony floor with its ends against the inside edges of the tower door opening. Be careful not to get glue in the holes.

2. To make the tower doors, follow the instructions under **Entry Doors** paragraph 1.a., substituting the words "tower door" where the instructions refer to "entry door." Handle the pivot pins and door edges as you did with the entry doors, trimming and rounding for a good fit.

3. Place the bottom pivot pins of both doors into the holes in the bottom threshold. There will be a large gap between the doors - this is correct. While holding these in place and tilting them outward slightly, place the top Tower Door Threshold on the top pivot pins. Glue the top threshold in place making sure not to get glue in the holes. The doors should now be in place and standing straight. Tape the threshold up against the bottom edge of the tower walls and allow to dry.

4. Cut four 6-3/4" pieces of Angled Molding (5-165) and glue two of them together as you did for the bay windows.



Glue these pieces into position between the two thresholds. The outside pieces fit against the angled molding at the outside edges of the doors, and the double piece fits into the gap between the doors. The double piece should be directly under the front post of the tower to form its natural downward extension.

Front Oriel Windows

1. Follow the diagram to construct the front oriel windows. Painting will be easiest if accomplished before assembly.

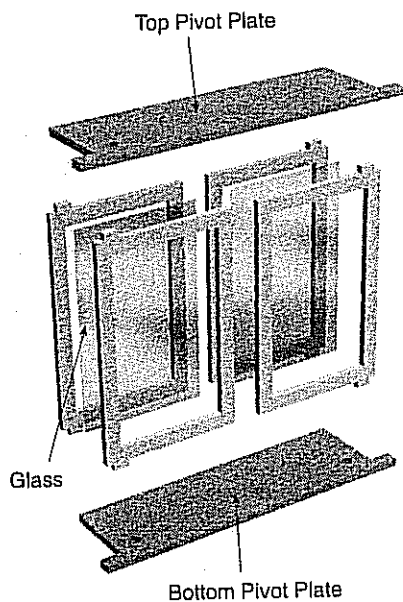

a. Assemble the two oriel windows - front, back, and glass as shown in the diagram.

i. Punch the scrap pieces out of the Front Oriel Window fronts and backs (1/8" plywood, Sheet MRM). Lay the Window Back best side down. Run a *thin* bead of glue around the opening in the Window Back (on the flat surface outside the hole, not on the inside edge of the hole). Place the appropriate piece of window glass on the Window Back (see box photo to determine which glass goes where).

ii. Run a bead of glue around the back side of the Window Front and center it on top of the glass and Window Back. Weight down or tape until dry.

b. Locate an Front Oriel pivot plate (1/8" plywood - sheet MRL) and place it into the bottom of the oriel opening with the sill protrusions forward. Glue the pivot plate down against the floor, being careful not to get glue in the pivot holes.

NOTICE: Windows will swing best and install easier if the edges of the pivot pins at the top and bottom of the window are sanded or trimmed so that the pins are approximately round. Do this before proceeding.

Also, sand the hinged edge of the window into a rounded shape to give it clearance to swing properly as you did with the entry and tower doors.

d. Now working from the front of the house, place the bottom pivot pins of the two window assemblies into the holes in the bottom pivot plate. Tilt the top of the window outward, put the top pivot plate onto the top pivot pins and then push it back into the oriel opening. Glue it into position and tape until dry.

e. Cut appropriate moldings and trims to fit around the window on the outside as seen in the box photo.

f. Cut appropriate moldings and trims to fit around the window on the inside. This means trimming the two sides with Corner Molding (5-8) and the top and bottom with Window Cornice/Sill (5-154).

Double Hung Windows

1. Follow the diagrams to construct the double hung windows. **Begin with the kitchen window.** Painting will be easiest if done before assembly.

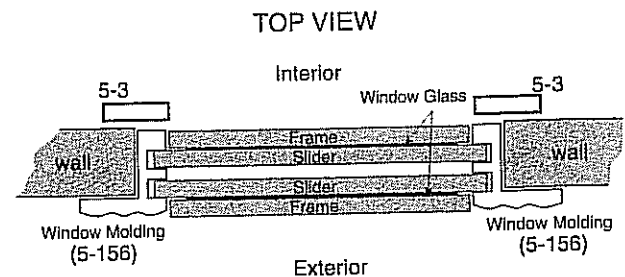

a. Start with a piece of universal trim 5-3 (not shown in illustrations) inside the window hole to cover the rough edges at the *top* and *bottom* of the window. Side edges will be covered later by the Moving Window Molding (5-156)

b. Punch the centers out of a rectangular Slider and

Frame (1/8" plywood). Lay the Slider best side down. Run a thin bead of glue around the opening in the Slider (on the flat surface outside the hole, not on the inside edge of the hole). Place a piece of glass on the slider (see box photo to determine which window glass goes where).

c. Run a bead of glue around the worst side of the Frame and center it on top of the glass and slider.

d. Repeat this process for the other Slide/Frame/Glass group. Notice that the glass in the bottom group is not the same as in the top (see box photo).

e. Cut two 2-3/4" pieces of Moving Window Molding (5-156). Glue one (only one) into the side of the window hole with the decorative molding side facing out. Run a bead of glue on the other side of the window hole in preparation for gluing the other molding in place, but don't position it yet! First put the sliders of the two windows into the grooves of both moldings (see illustrations), and then swing the entire assembly into position. Hold or tape until the glue takes hold.

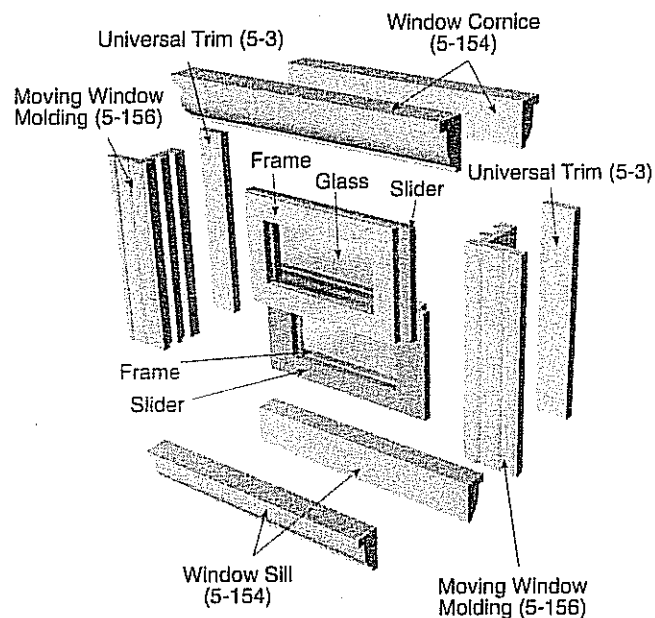

f. Cut and glue two 2-3/4" pieces of universal trim (5-3) to trim the sides of the window on the inside.

g. Cut and glue the Window Cornice (5-154) on the outside and the inside. These pieces can be mitered at the ends if desired (see box photo).

h. Cut and glue the Window Sill (5-154) on the inside and outside.

Note: We are of the opinion that it makes little sense for the top window in a double hung dollhouse window to be movable. It tends to drop down when it shouldn't, and there is very little reason for it to move anyway. We designed it to move so that you would have the option, but there may be some value to gluing it in place and letting the bottom window do the moving. Your choice.

2. With some exceptions, you will now repeat the above process for each of the two side bay windows.

a. First exception. You will not need the universal

trim (5-3) that you used in the opening of the kitchen window – paragraph 1.a.

b. Second exception. For the double hung bay windows, the two pieces of Moving Window Molding (5-156) will be 6-7/8" long.

c. Third exception. When installing the Window Cornice and Window Sill (5-154), you may wish to miter the appropriate ends at 22.5° in order to make them butt against each other at the corners of the bay (see box photo). While this isn't necessary to have a beautiful dollhouse, it does conform more closely to the actual building techniques used in most Victorian houses.

Simple Windows

There are four tower windows (8 plywood pieces + glass), and a large center bay window (2 plywood pieces + glass). Making these windows is a simple matter of sandwiching glass between identical plywood pieces and then gluing them into position. Use the box photo to help you decide which pieces of glass to use.

Oxeye Window

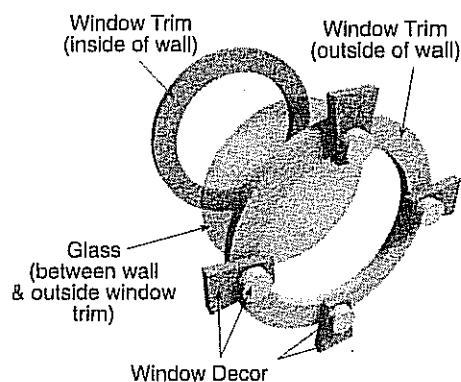

1. Use the illustration as a guide to construct the oxeye window. Painting will be easiest if accomplished before assembly. Window glass goes between the exterior round trim and the outside of the wall.

Bow Windows

1. Cut eight 9-9/16" pieces of Angled Molding (5-165). Glue six of them together into three pairs as you have done before. Set them aside while the glue dries.

2. Locate the two Bow Window Templates (1/8" plywood – sheet MRD). Positioning of the templates is critical, so please take extra care with this step. Start with the bottom template which glues flat down against the second floor. The outside flat edges of the template should fit against the inside surfaces of the top bay walls (MR39 & MR40). The front edge of the template should be flush to the front edge of the Second Floor Bay (MR3) – NOT the front edge of the wall, but the floor! See illustration.

Put something heavy on the template until the glue dries.

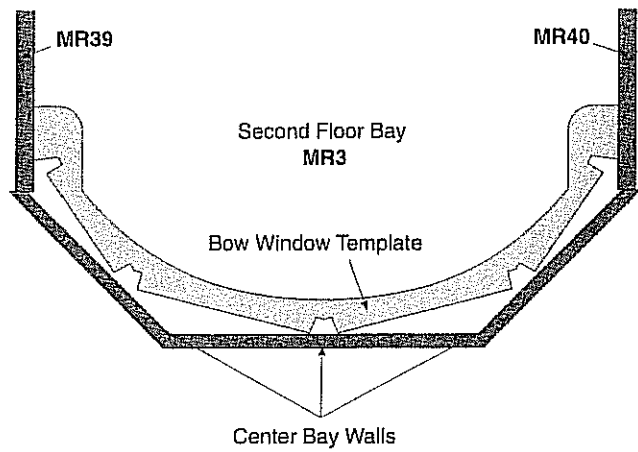

3. Using the same technique, glue the top template in place against the underside of the Third Floor Bay. This template must be positioned exactly above the bottom template. Tape in position. While the glue is still wet, stand one of the double Angle Molding posts from paragraph 1 in the notches in the center of the two templates. It should stand exactly vertical from all angles. If not, adjust the top template until the post stands properly, and then tape the template securely until dry.

4. When the glue has dried, glue the two single posts into the outside notches. Put the bottom of the post in the bottom notch, tilt the post inward, then push the top of the post into the top notch. These are a tight fit, and they may need to be pressured a little to get them in. Don't overdo it, though, because we don't want anything to break. If moderate pressure doesn't get the post to snap into place, sand the end a little until it fits.

5. Now glue the three double posts into the remaining notches.

6. Locate the four Side Bow Window pieces and the four Center Bow Window pieces. Use the window glass to make a window sandwich as you have done before. From the back of the house, glue these windows into place between the posts that you positioned earlier.

7. Using the box photo as a guide, cut pieces of Window Sill/Cornice molding (5-154) to fit horizontally between the posts and against the window frames. Glue them in place to form sills and decorative molding.

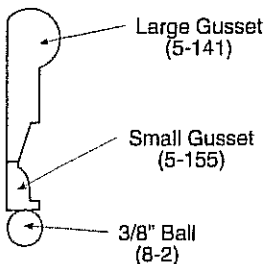

8. The decorative brackets that add detail at the top of the bow window and bay window posts are made from three pieces each – Large Gusset (5-141), Small Gusset (5-155), and 3/8" Ball (8-2). Assemble as shown.

Porch Rail

1. Locate a long piece of Porch Rail Top molding (5-71) and a long piece of Porch Rail Bottom molding (5-70). Cut 20" lengths of each. Lay the Porch Rail Top molding on your work surface with the slot toward you and the Porch Rail Bottom molding with the slot away from you. Beginning from the left edge, put a small pencil mark every 5/16" across both pieces.

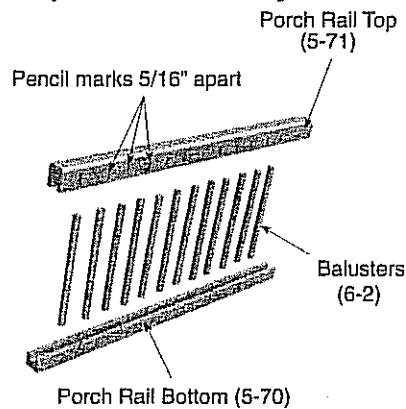

Locate the 1/8" x 2" Baluster dowels (6-2) and glue them into the slots at the pencil marks. See illustration. Be sure that the dowels are parallel, the top & bottom rails are parallel, and everything is square. This will provide adequate balustrade to make the porch rail and the tower rail inside the house (more about this later).

2. Repeat this procedure, but this time cut the baluster dowels (6-2) in half to make 1" balusters. This will be used for the decorative rail on the balcony. You will need about 4" of this balustrade.

3. Cut a length of the 2" balustrade from paragraph 1 that fits exactly between the right front porch pillar and the right back porch pillar (approx. 5-7/8 inches). Glue it into position between the pillars. It should be about 1/8 inch off the porch floor.

4. Cut a 2-1/2" post from the Porch Post Molding (5-6). Chamfer (bevel) the upper edges of the post slightly by sanding. Glue a 3/8" Ball (8-2) to the top of the post. This post is the back porch post on the left side of the porch.

5. Cut a 2" length of the 2" balustrade from paragraph 1. Position it between the front left porch pillar and the post that you made in paragraph 4. This will form the left side porch rail. Again, the bottom of the balustrade should be about 1/8" above the porch floor.

6. Cut a 2-1/2" piece of 1" x 1" pillar base (5-164). Center and glue a pedestal cap (1/8" plywood) on top. Center and glue a 3/8" Ball (8-2) on top of the pedestal cap. This post is the center front porch post (see box photo).

7. Cut a 2-1/2" piece of 2" balustrade from paragraph 1 and glue it between the front left porch pillar and the post that you made in paragraph 6. The front edge of the post should be flush to the front edge of the porch floor, and the bottom of the balustrade should be about 1/8" off the porch floor.

Balcony Rail

1. Cut two 1-5/8" pieces of 1" x 1" pillar base (5-164). Glue on a pedestal cap and a 3/8" Ball as before.
2. Cut two 1-3/4" pieces of Porch Post Molding (5-6). Chamfer (bevel) the upper edges of the post slightly by sanding. Glue a 3/8" Ball (8-2) to the top of each post.

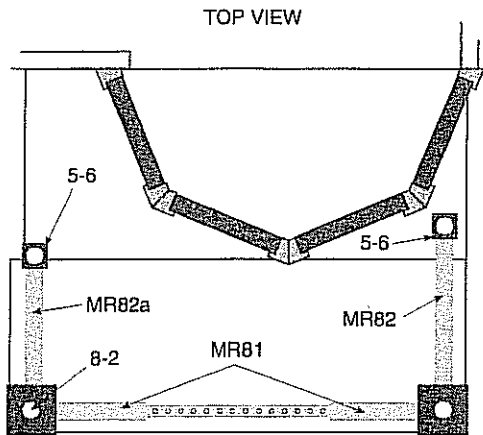

3. Locate the four pieces of Balcony Rail MR81(2), MR82a, and MR82. Locate the 4" length of 1" balustrade that you made in paragraph 2 of the previous section. Using the top view diagram and the box photo as your guides, set up the balcony rail.
4. Locate the four pieces of Balcony Rail Caps (1/8" plywood) and glue them on top of the balcony rail pieces.

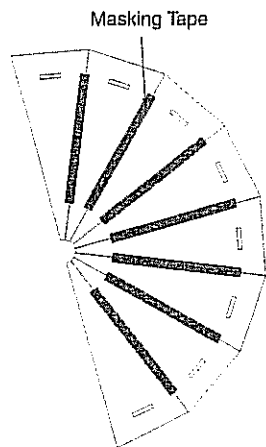

Tower Roof

1. Locate the eight triangular pieces of tower roof (1/8" plywood – sheet MRN). There are hash marks on the edges of each piece. Using a straight edge, draw pencil lines across each piece between each pair of hash marks. These pencil lines will serve to mark the location of roof shingles later.

2. Turn the roof pieces best side down on your work surface and place them edge to edge as shown. The pencil lines should NOT be visible – they should be on the underside of the pieces. Tape the pieces together with masking tape.

3. Form a cone with the masking tape on the inside by bringing the two untaped edges around to meet each other. Tape these two edges together on the inside of the cone.

4. Locate the Tower Roof Support (1/8" plywood – sheet MRJ) and push it into the opening in the tower cone until the tabs all engage the slots. Glue.

5. Run a bead of glue down the valleys between the roof pieces on the outside of the cone. Tape the cone together while the glue dries.

6. Glue the finial (5-94) into the top of the tower roof.

Corner Trim Pieces

1. Locate some corner trim molding (5-8). Cut pieces to cover each of the outside corners – use the box photo as your guide.

Where you feel it is necessary or to some decorative advantage, cut pieces of universal trim (5-3) to place vertically against the inside corners.

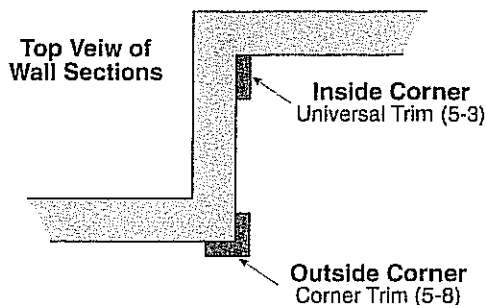

Eaves

1. Edge glue the Right Eaves (MR80) against the front edge of the Right Main Roof (MR52) Notice: "Eaves" is a plural noun that has no singular form – no such word as eave. The Right Eaves is only one piece.
2. Edge glue the Left Eaves (MR79) against the front edge of the Left Main Roof (MR53) with its top end against the under side of the Right Eaves (MR80).
3. Using a straight edge (ruler), extend your pencil lines from the main roof pieces onto the eaves.

Porch Lath

1. Locate the four pieces of porch lath (1/8" plywood – sheet MRO). Glue them to the porch foundation. Start with the Left piece – the front edge of the lath is flush to the front edge of the foundation. Next glue the right piece – its front edge is also flush to the front edge of the foundation. Then glue on the two front pieces. They cover the front edges of the other two pieces. There is a large gap between the two front pieces: this gap will be covered by the steps.

Porch Steps



1. Locate the 5 Porch Steps (6-27). Glue them together as shown.

2. Locate the six pieces of Porch Step Rail (MR83, MR84, and MR85: 2 each). Edge glue

them together and then glue them to the ends of the steps as shown.

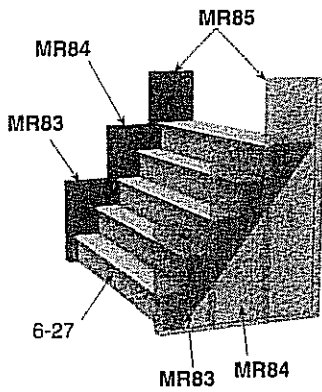

3. Glue this assemblage to the front of the porch. The back edges of MR85 should fit against the porch lath with the top ends against the porch pillars (see box photo).

4. Cut two 2-5/8" pieces of porch post (5-6), chamfer (bevel) the top edges, and glue them to the front of MR83.

5. Locate six 3/8" Balls (8-2) and glue them to the posts and porch rail (see box photo).

Side Oriel

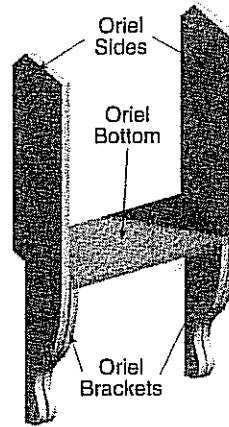

1. All of the pieces for the side oriel are located on sheet MRK of the 1/8" plywood.

2. Start by gluing the Oriel Brackets to the inside surfaces of the Oriel Sides. Then glue the Oriel Bottom between the two side pieces with its bottom surface against the tops of the brackets.

3. Glue this assembly into the opening in the top of the right side wall. The Oriel Bottom sets on the bottom of the opening, and the brackets set back against the wall.

4. Glue the two Oriel Roof pieces onto the Oriel Front by inserting the tabs into the slots. Run a bead of glue along the little valley between the two roof pieces and then tape them together while the glue dries.

5. Glue the Roof/Front assembly onto the oriel sides. The bottom edge of the Oriel Front should cover the front edge of the Oriel Bottom.

6. Glue the appropriate window glass in place against the front. Glue the Oriel Window Frame onto the front so that it covers the edges of the glass and frames the hole.

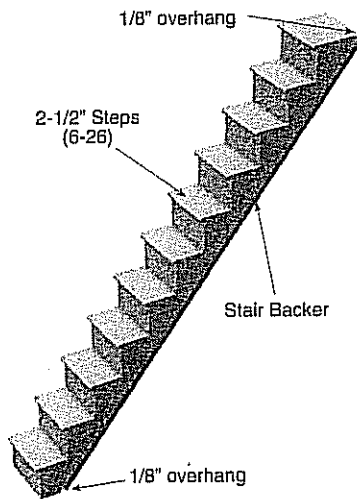

Inside Stairs

1. Locate 13 Stairs (6-26) and a Stair Backer (1/8" plywood). Using the illustration as a guide, begin at the bottom of the Stair Backer and glue each stair in position until you reach the top. Notice that the first step and last step are approximately 1/8" off the ends of the backer. This makes it possible for these two steps to fit flush against the first floor and second floor without the

backer interfering. Notice: This illustration shows only 11 steps – the Marquam Hill Mansion Kit (MR625) actually uses 13 steps.

2. When the glue from step one is dry, glue the stairway in place with the top step inside the stairwell hole and flush with the top of the second floor. See box photo for positioning. Paint before gluing.

3. Measure and cut pieces of Universal Trim (5-3) to cover the interior edges of the stairwell hole.

4. Repeat the entire process for the next stairway.

Chimney

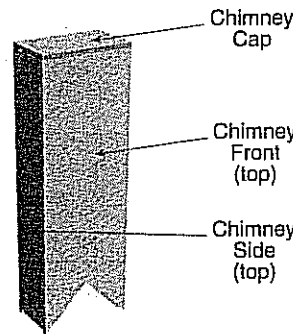

The chimney is in three sections – Bottom, Center, Top. They are all made of 1/8" plywood.

1. Locate the 5 pieces of the chimney top. Assemble as shown.

2. Next, let's do the bottom. Locate the bottom right, left, and front pieces. Also find the Chimney Splicer, Fire Place Floor, and Chimney Support Bottom.

3. Lay out the front and two side pieces (face down) and make a horizontal mark 4-1/4" up from the bottom. This mark will define the position of the Fire Place Floor. Glue the Fire Place Floor perpendicular to the chimney front as shown, with the upper surface against the pencil mark that you just made. Then glue on the side walls (flush to the bottom), the chimney support bottom, and the chimney splicer.

BACK VIEW FRONT VIEW

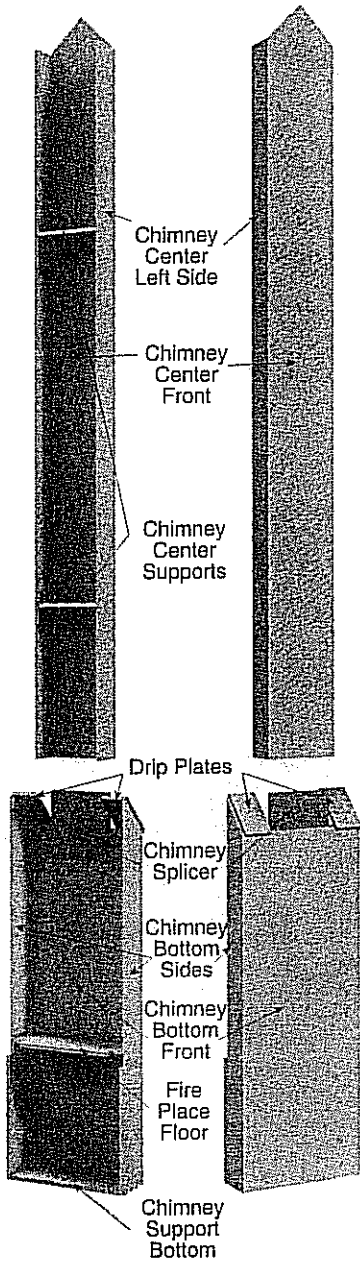

4. Find the 3 chimney center pieces and the 2 Chimney Center Supports. Glue them as shown. Using the chimney splicer as the glue connection, glue the center to the bottom now. The bottom edge of the Chimney Center Front should rest on the top edge of the Chimney Bottom Front.
5. Find the Drip Plates and glue them in position.
6. Dry fit the chimney against the left wall to ensure a proper fit before adding stone work.

Foundation Stonework

1. Before applying the stone pattern, take a moment to consider what color your mortar lines will be. Some intermediate shade of gray is most natural. Paint the foundation walls. Wait for the paint to dry thoroughly.
2. Peel the webbing from the Stone Tape (7-3) as shown.

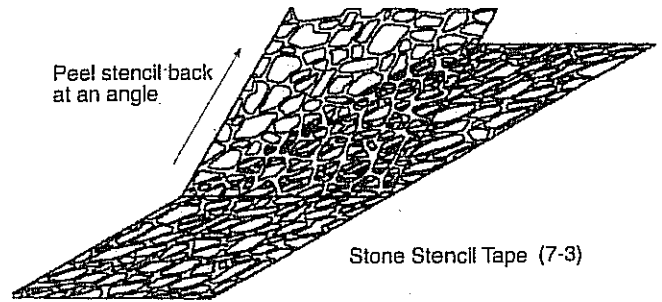

3. Stick the stencil to the foundation wall leaving enough overhang at the corner to hold onto for removal. Press firmly for full contact – otherwise, you may have stone material seeping under the template into the mortar area. *We suggest doing only one side at a time.*
4. To cover one foot of stone template tape it takes 1-2/3 ounce or 2 tablespoons of stone powder. Put about 4 tablespoons of tacky glue (or other white glue) into a cup, add an equal amount of water to the glue. Mix well. Put the appropriate amount of stone powder for the length of surface you are going to stone into a different cup. Slowly add small amounts of glue mixture to the powder (It is easy to add too much glue mixture, so proceed with caution). Mix after each addition. Continue until mixture starts to hold its own shape like cake frosting.

TIP: The stone mix in your kit will produce white stone. This provides good looking stone in most cases, but you may want to add paint to the mixture to achieve a different color of stone for your house. Adding paint may result in a mixture that is too dry or too wet, so you may need to add water or stone powder to get the consistency of cake frosting.

5. Spread stone mix over the webbing with a putty knife to about 1/16" thick.
6. Remove webbing within 5 minutes. Stick the overhanging webbing to a piece of scrap wood and pull as you did when taking the webbing off of the backing. The wood handle will help pull the webbing off evenly.
7. If needed, touch up the stones with a small piece of wood while the stones are still soft. Wait for stones to dry on one surface before proceeding to the next.
8. Doing stone work on the chimney is very similar to the stone work that you did on the foundation. Try not to get stone powder on the back edges of the chimney sides where the chimney will glue to the house.
9. Do the stone work on the chimney assembly and the

chimney top assembly separately. Glue all pieces on the house when completely dry. The Fireplace Floor should extend into the fireplace opening. Be sure that the *bottom* edge of the fireplace floor is flush with the first floor of the house. When you position the Hearth from the inside (next step), it will butt up against the fireplace floor. Take time now to ensure that the top (which glues onto the roof) is lined up properly with the lower part of the chimney.

Third Floor Rail

1. Inside the house, the third floor is open to the floor below at the tower. Place a 7-1/4" length of 2" balustrade across this opening. It will be most stable if glued directly to the floor.

Mantel

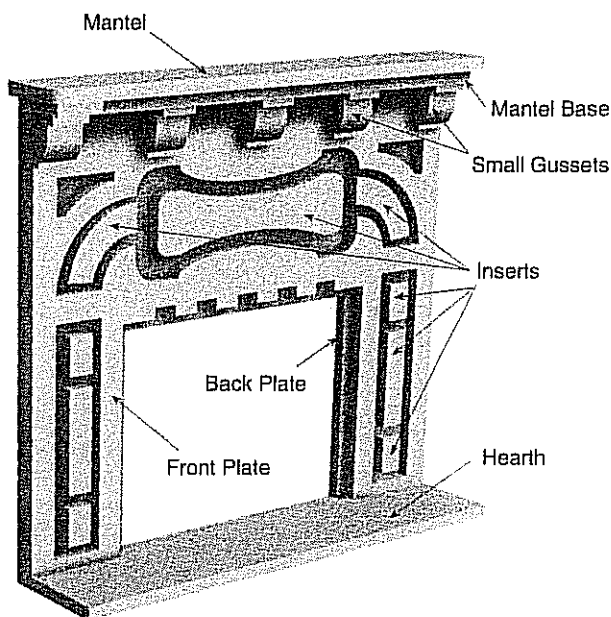

1. Locate all of the mantel and fireplace pieces (1/8" plywood). Glue them together as shown. Start by gluing the Fireplace Front Plate to the Fireplace Back Plate. Fill in the 9 Fireplace Insert pieces. Glue 5 Small Gussets (S-155) flush to the top of the mantel front plate as shown. Glue the Mantel base to the gussets and then the mantel on top of that.

Glue the assembly in front of the fireplace opening in the left wall. Glue the Hearth in position.

Roof Shingles (Shakes)

IMPORTANT: Building a perfect shake roof requires an understanding of the methods used by roofers in the real world. Shakes are not uniform in width or color, so you need to apply them with these natural variables in mind. At Dura-Craft, Inc., we have gone to extra effort to ensure

that you receive a suitable variety of widths and colors. If you create your dollhouse roof with care, it will have a truly authentic, real world look.

Take a look at the illustration. The first thing you will notice is the appearance of randomness. This is exactly how professional roofers arrange shakes. While making your dollhouse roof, you should keep a constant eye toward mixing up the colors and widths.

Even more important, the spaces between shakes are arranged so that no space between shakes lines up with a space in the row below it.

If you approach your dollhouse roof in the manner shown, you will make the best use of the shakes that Dura-Craft, Inc. has supplied for you, and you will have a dollhouse roof that you can be proud of.

You should not attempt to sort out shakes of a particular size or color in an effort to make a uniform roof. You will lose the wonderful authenticity of the Dura-Craft, Inc. roofing method, and you will run out of shakes long before your roof is complete.

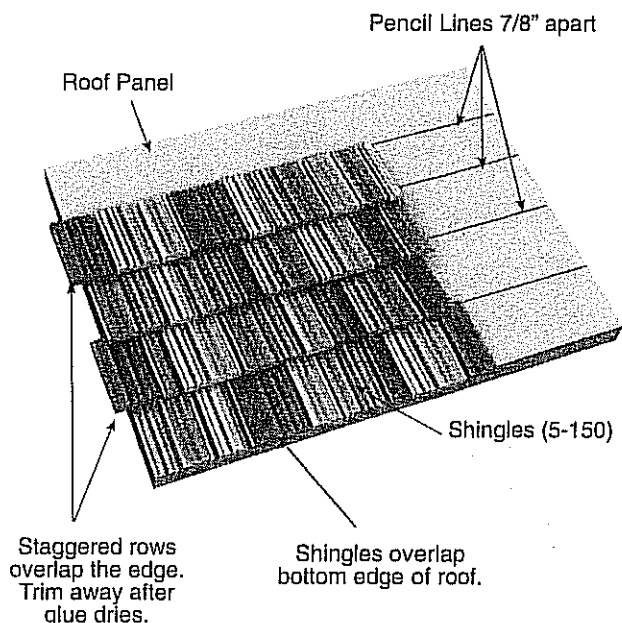

1. Remember those lines you drew on the roof parts? Well, now is the time to put them to use. Beginning at the bottom edge of each piece, glue a full row of shingles (S-150) with the top edge of the shingles on the line. The bottom of the shingle will hang over the bottom edge of the roof. When the bottom row is complete, begin the next row and work your way to the top. See "important" information at the beginning of this section for the best approach.

2. At straight roof edges, overlap the edge with the shingles. When the glue is very dry, you can easily trim the shingles flush with the roof edge.

In valleys and where roof edges are angled, you must cut shingles to fit the angle before gluing.

When you have completed the main roof pieces, do the tower roof.

Final Trim

1. Using the box photo as a guide, cut and position trim pieces on roof edges. Pieces can be cut from fascia trim (5-158). When fascia trim is in position, glue the Main Gable Decor (1/8" plywood – sheet MRL) in position above the oxe-eye window on the main gable. (Optional and not shown on box photo). This piece fits up against the underside of the roof and at the front edge of the roof, just behind the fascia trim.

2. Cut a piece of Porch Post (5-6) to fit across the Top Bay Wall and under the front oriel. See box photo. Glue small gussets (5-155) to make corbels under this beam.

3. Locate the Front Oriel Decor (1/8" plywood – sheet MRK), and the Tower Decor (sheet MRM). Use the box photo to locate their position. Glue them on now.

4. Locate the large Front Brackets (1/8" plywood – sheet MRG). Glue them together in pairs to achieve a 1/4" thickness. Glue the two brackets to the front edges of the top bay walls near the bow windows. See box photo.

5. Glue universal trim (5-3) along the right edge of the tower where it meets the right wall. Also glue universal trim along the edges of the bay and bow windows. On the left side, this piece should run all the way from the bottom of the wall, up along the back edge of the bay window, along the front edge of the Bay Wall Left (top), and up under the roof.

6. Use the remaining moldings to "finish" the trim on the inside and outside of the house. The box photos will help if you are unsure, but this is your house, and there is no right way to trim it. Don't hesitate to do what feels right even if it isn't exactly like our picture on the box.

7. We have included a little bit of extra molding in the kit for those of you who want to add things that we didn't think of. You may wish to customize your house and add features you specifically want. We encourage innovation.

Congratulations! Enjoy.

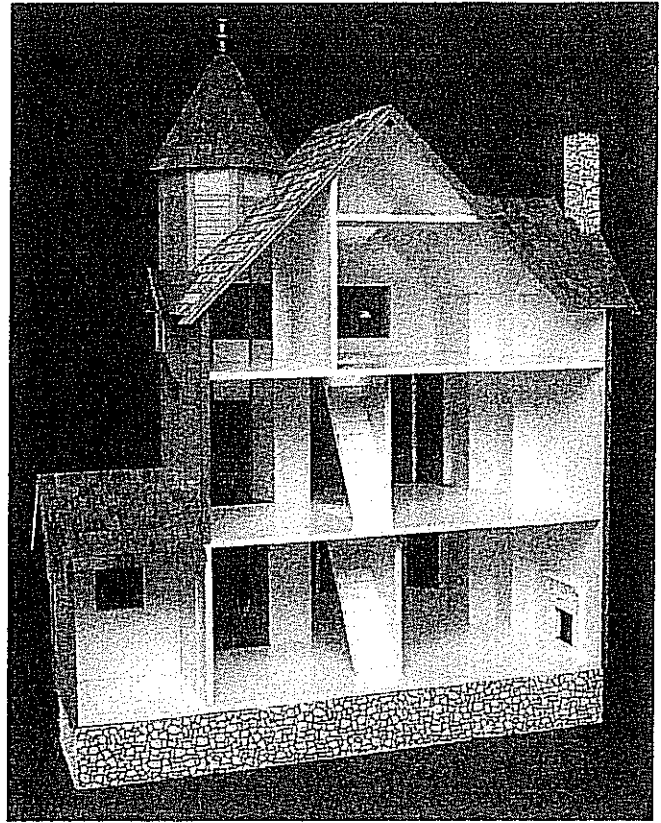

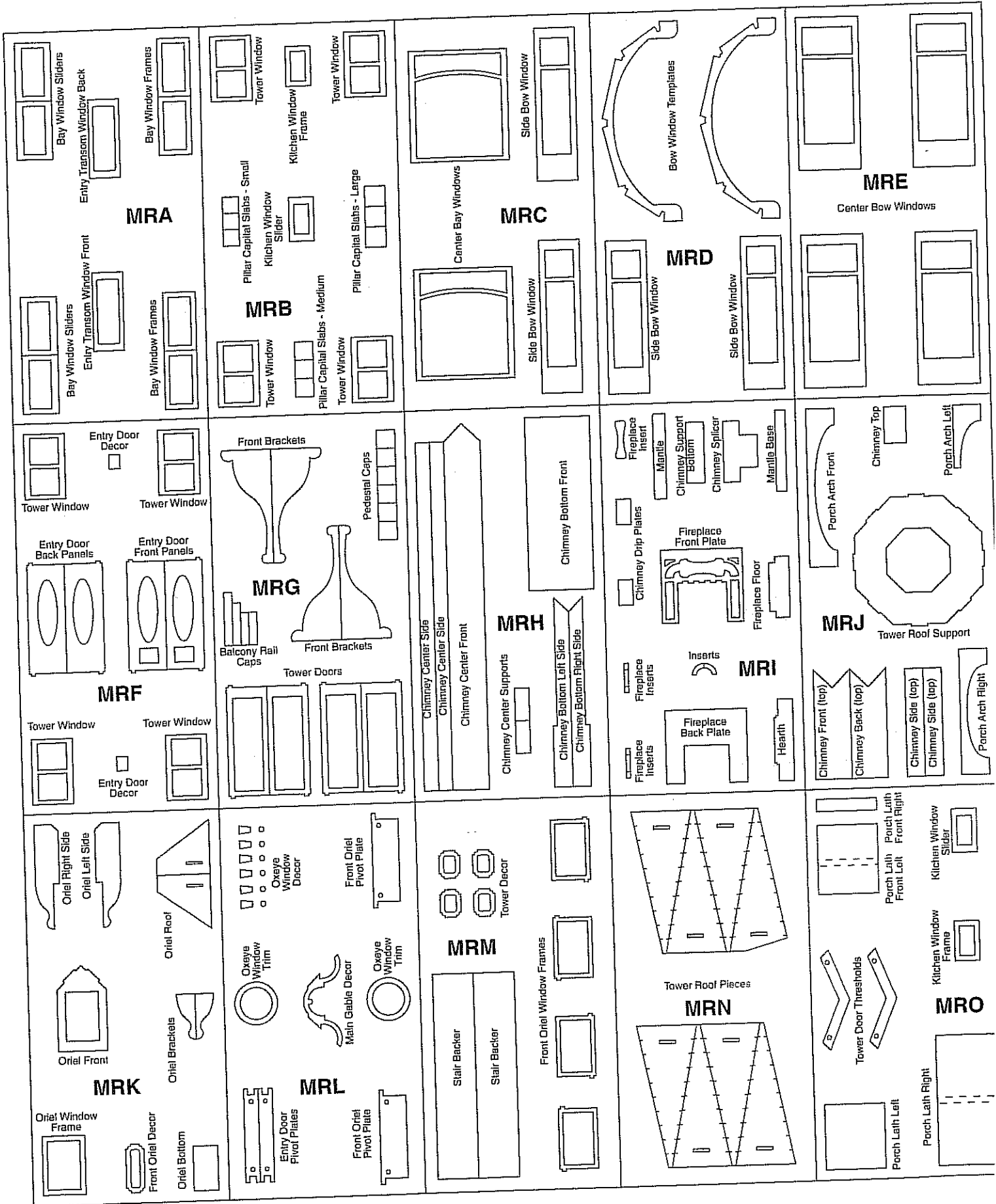

Medium Density Fiberboard (MDF) Pieces

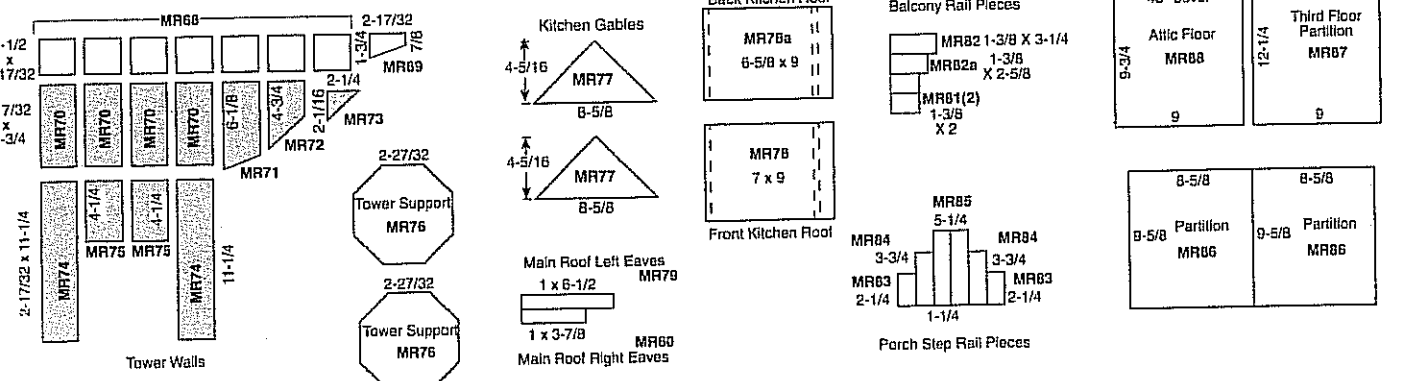
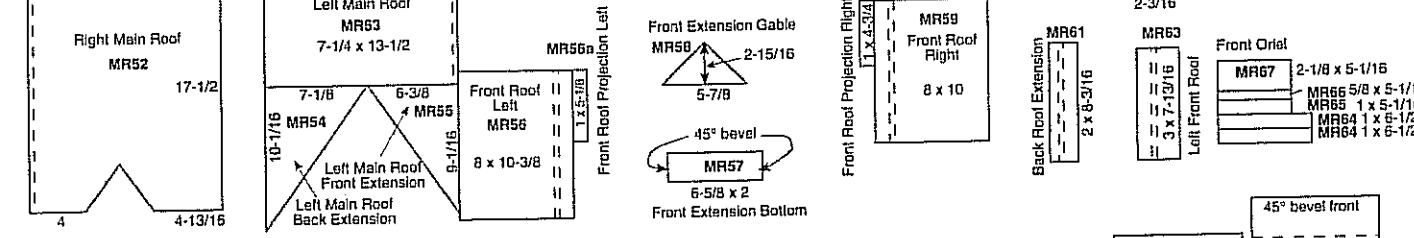
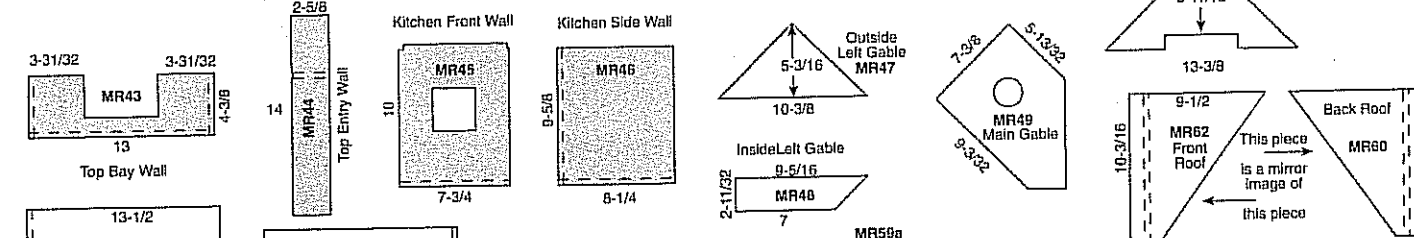
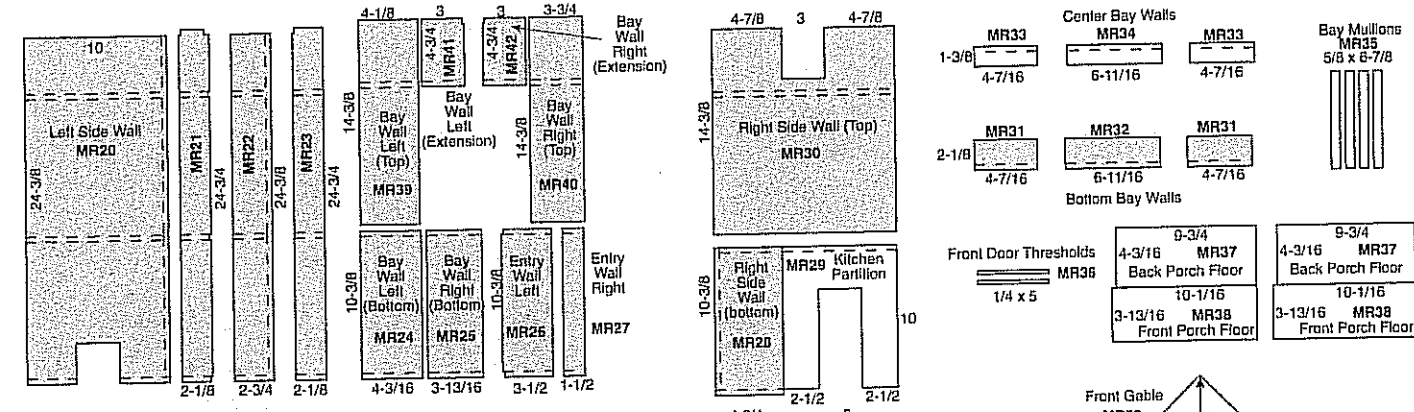
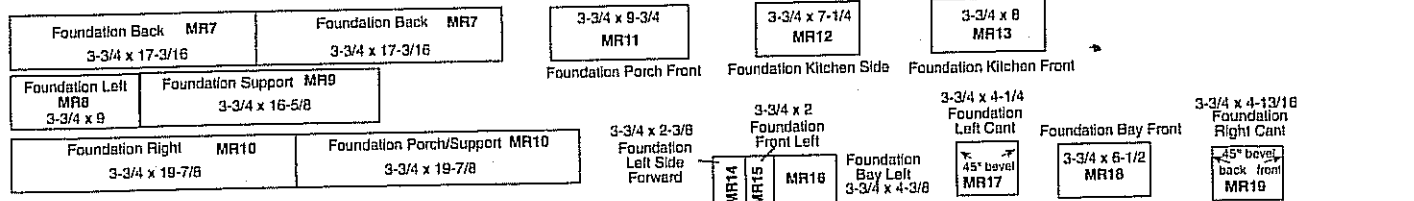
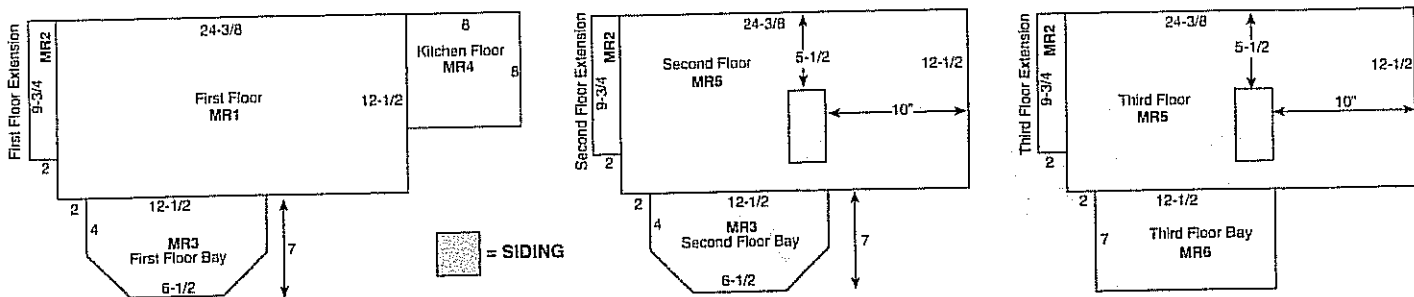

Part No. 5-3



Universal Trim

Part No. 5-5

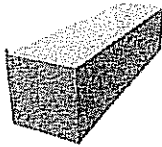

3/8" x 3/8"

Part No. 5-6

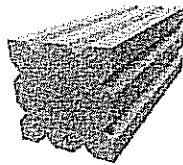

Porch Post

Part No. 5-8



Corner Molding

Part No. 5-165



Angled Molding

Part No. 5-70



Porch Rail Bottom

Part No. 5-71



Porch Rail Top

Part No. 5-94



Finial

Part No. 5-141



Large Gusset

Part No. 5-154



Cornice/Sill Molding

Part No. 5-155



Small Gusset

Part No. 5-156

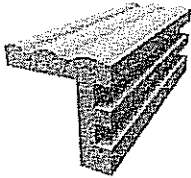

Moving Window Molding

Part No. 5-158



Fascia Trim

Part No. 5-160

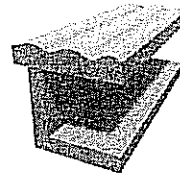

Door/Window Molding

Part No. 5-164

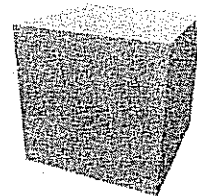

1" x 1"

Part No. 6-2

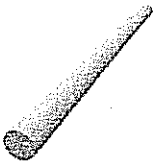

Dowel

Part No. 6-17



Door Knob

Part No. 8-2



3/8" Ball

Part No. 6-26

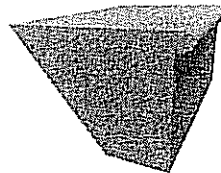

Steps (2-1/2")

Part No. 6-27

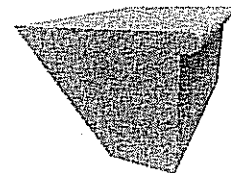

Steps (5")

Part No. 5-150



Plain Shakes
(Shingles)

Part No. 7-3



Stone Tape

Part No. 7-4

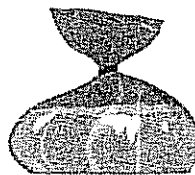

Stone Mix