

FARMHOUSE

FH 505 MINIATURE HOUSE KIT ASSEMBLY INSTRUCTIONS

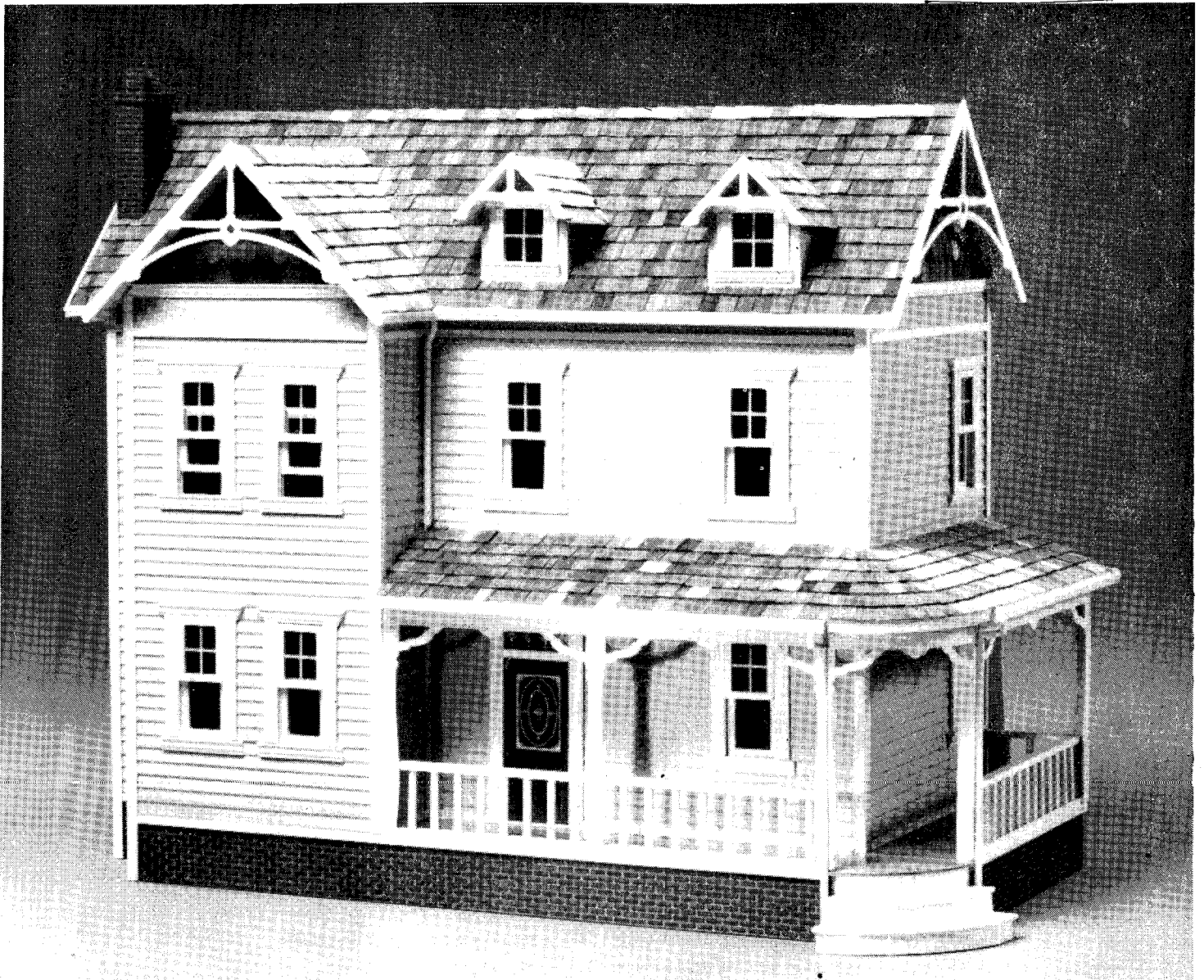

FINISHED SIZE: 32 1/2"H x 42"W x 22"D

SCALE: 1"=1'

Dura-Craft, Inc.

P. O. Box 438
Newberg, OR 97132
(503) 538-3136

FARMHOUSE

FH 505 MINIATURE HOUSE KIT

Congratulations on selecting a miniature house kit manufactured by Dura-Craft, Inc., the leader in the industry. We pride ourselves in our high quality and workmanship. Each piece is graded and sorted at several different stages to ensure that you receive the finest quality.

A Dura-Craft miniature house is a complete kit. You will not have to make separate purchases of items like the windows and shingles which are a basic part of your house.

If ample time and care are used in construction and finishing, your house will be of heirloom quality, of which you will be justly proud.

READ BEFORE STARTING ASSEMBLY:

The following tips will help you avoid problems when you build your miniature house.

1. **Save The Box** - The photo will be very helpful during assembly.
2. **Read Instructions First** - Before beginning construction of your miniature, read through all instructions to get a feel for the assembly process and to gain familiarity with the parts.
3. **Follow Instructions In Order**
4. **Don't Force Pieces** - If you cannot release a part from its board with moderate pressure, carefully cut it loose with a utility knife. Always cut from the good side of the board where the cut lines are clearly visible.
5. **We Will Replace Parts** - If any parts are missing or damaged, Dura-Craft will quickly replace them at your request. Please write or call and give us the name and sheet number of the part or parts that you need. We have included a "Missing and Broken Parts Replacement Form" to assist you. It may save time to make missing or broken parts from the scrap material.
6. **Use Tacky Glue** - This glue helps hold parts in place while it dries and it dries clear. It can be found at most craft supply stores. Any white household glue or woodworking

glue may be substituted if desired.

7. **Each Part Is Important** - Dura-Craft has done everything possible to ensure that your kit will look good when it is complete. We have included pine moldings to strengthen the house and trim to cover all of the outside wall and floor edges. We have also designed the kit so that slot and tab positions will be hidden when the kit is finished. However, the final quality of your house will depend to some extent on the care you take in preparing each piece for assembly. Sanding is optional, but it will improve your house and help parts fit better.

8. **Keep House Dry** - At no time should the house be placed in a cold damp area.

9. **Materials List** - You will need the following materials to assist you in the assembly of your miniature house:

- Glue (see paragraph 6 above)
- Utility knife or sharp, sturdy knife
- Masking tape
- Damp cloth or paper towels
- Ruler or tape measure
- Fine toothed saw such as a coping or hacksaw is helpful
- Pencil
- Medium and fine sandpaper
- Wax paper
- Several large books to use as weights
- Framing square
- Contact cement (oil or neoprene)
- Steel wool (for hardwood flooring)
- Small "C" clamps come in handy
- Sanding sealer (oil base)
- Paint (oil or latex)
- Wallpaper paste (optional)
- Spray adhesive (for carpet - optional)
- Large baggies

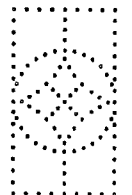
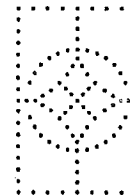
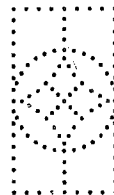

FH 505 FARMHOUSE REVISIONS -3-11-97

Please use these revised figures with the existing written instructions.

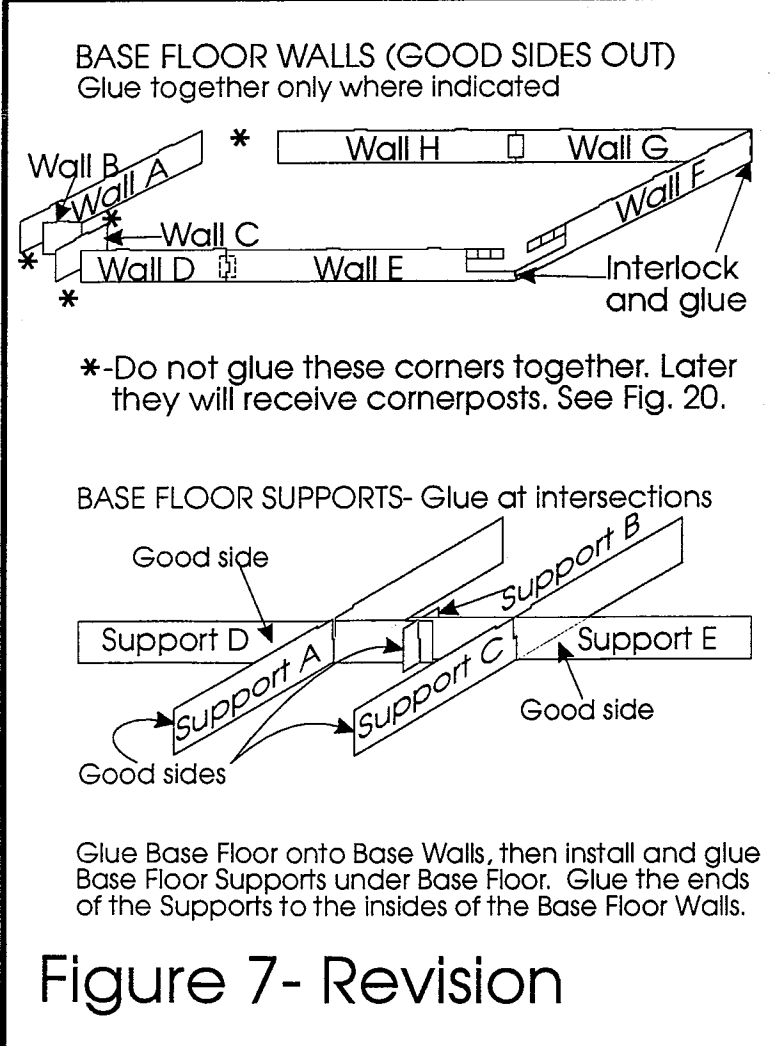
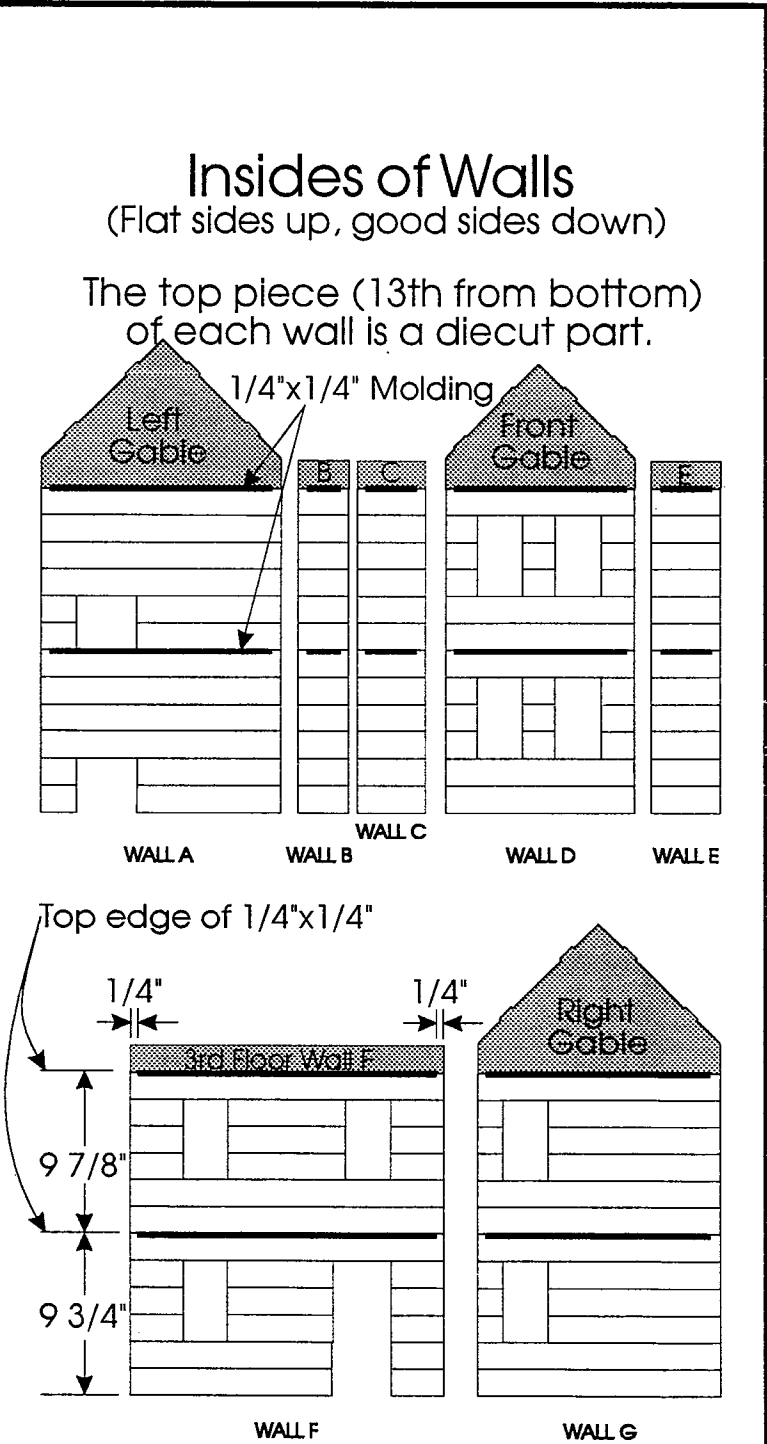
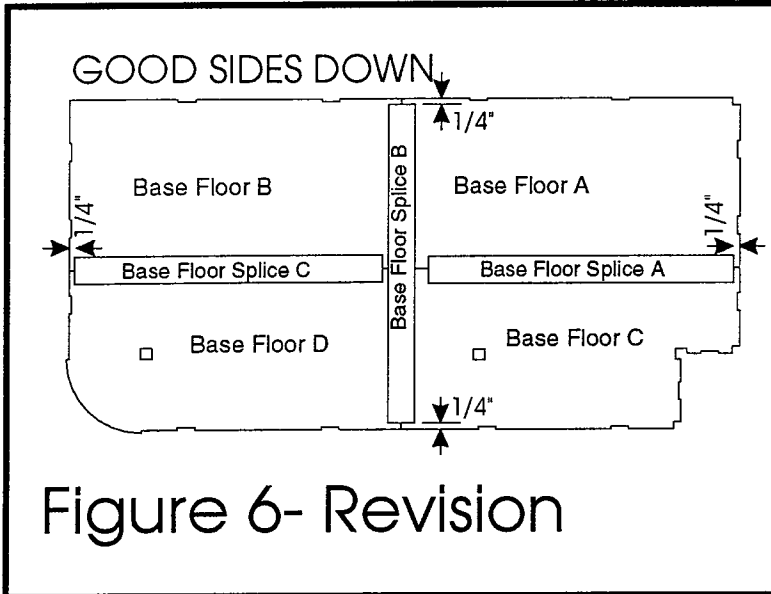

Figure 19- Revision

FH 505 FARMHOUSE REVISIONS -3-11-97

Please use these revised figures with the existing written instructions.

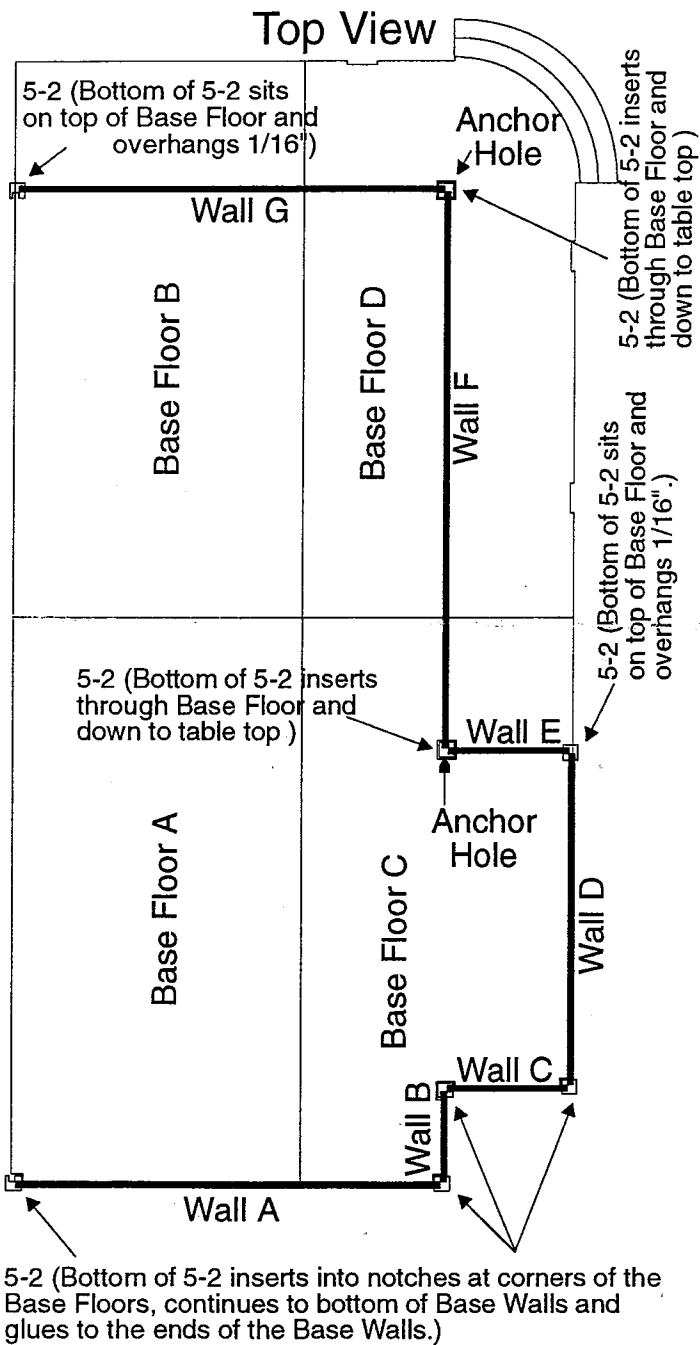

Figure 20- Revision

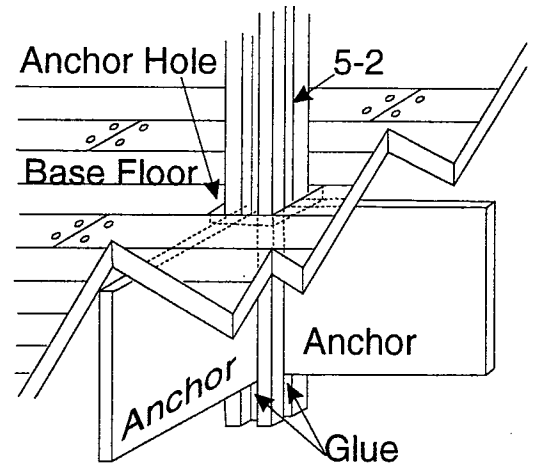

Figure 21- Revision

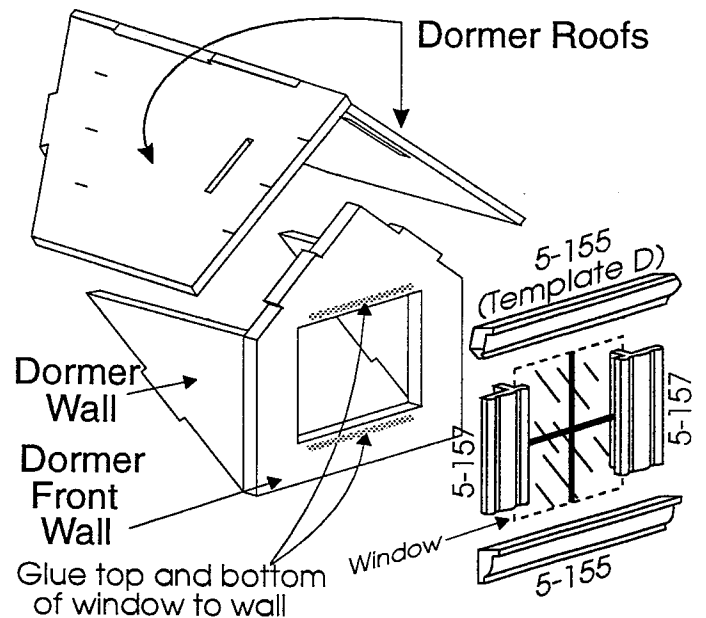

Figure 25- Revision

GLOSSARY:

Good Side: The side the pieces were stamped from; the smoothest side.

Bead of Glue: A line of glue approximately the size of a pencil lead.

": Inches

Flush: When the edges of two boards are even.

Left and Right Sides: All references will be made from the front view, unless otherwise instructed.

Tab: A projection off the edge of a board.

Slot: A hole in a board that a tab fits into.

Notch: The same as a slot except it's on the edge of a board.

Glass: Silkscreened plastic sheets.

Part No. 6-6
40 pc.



Large Dowels

Part No. 6-2
47 pc.



Small Dowels

Part No. 5-143
65"



Downspout

Part No. 5-3
800"

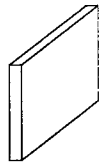

Universal Trim

Part No. 5-142
75"

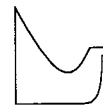

Gutters

Part No. 6-19
1 bundle



Hardwood Flooring

Part No. FH - 1 thru 28
28 stamped sheets of parts
(see back of instructions)

Siding:

| Part No. | Length | Quantity |
|----------|---------|----------|
| 1-41 | 1 1/2" | 6 |
| 1-38 | 1 7/8" | 18 |
| 1-11 | 2" | 4 |
| 1-4 | 3" | 12 |
| 1-32 | 3 1/8" | 14 |
| 1-19 | 4" | 24 |
| 1-39 | 6 1/4" | 3 |
| 1-31 | 7" | 3 |
| 1-14 | 8 1/2" | 4 |
| 1-42 | 9 7/8" | 6 |
| 1-17 | 11" | 6 |
| 1-44 | 11 7/8" | 2 |
| 1-2 | 14" | 14 |
| 1-16 | 18 1/2" | 4 |

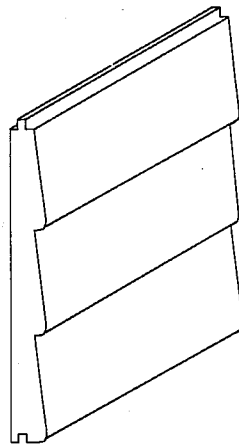

Part No. 5-150
1 package

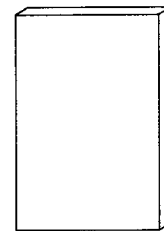

Plain Shakes

Part No. 5-151
1 package

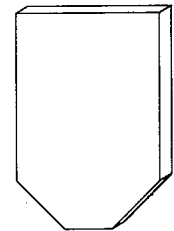

Fancy Shakes

Part No. 6-18
2 pc.



Hinge Pins

Part No. 6-17
2 pc.



Door Knobs

Part 7-1
19' of Brick Tape

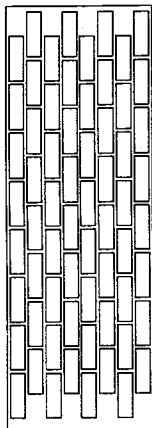

Window Glass

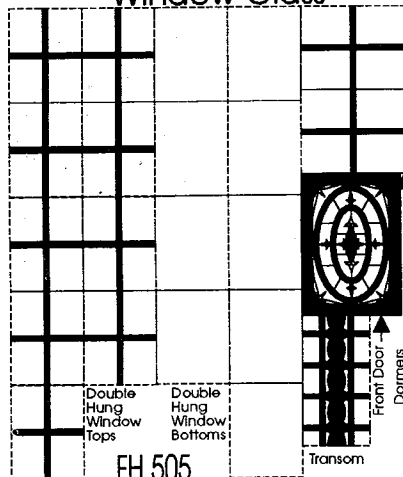

FH 505

Part 7-2
19 oz. of Brick Mix

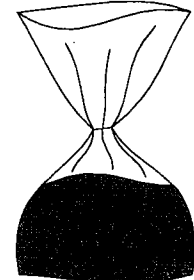

Part No. 5-37
3 pc.

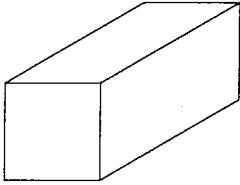

Porch Posts
1/2"x1/2"x9 3/4"

Part No. 5-46
150"

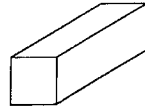

1/4"x1/4"

Part No. 5-24
34"

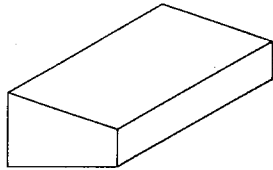

Porch Roof Support

Part No. 5-70
140"

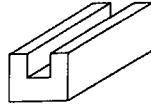

Small Edge Trim

Part No. S5-2
68"

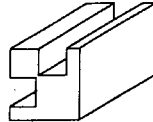

Small Corner Post

Part No. 5-2
200"

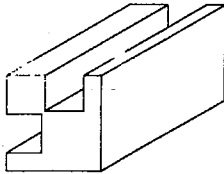

Large Corner Post

Part No. 5-155
320"

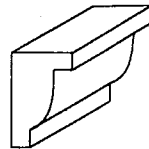

Small Bracket Longframe

Part No. 6-4
80"

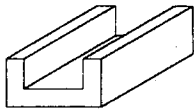

Large Railing Trim

Part No. 5-157
30"

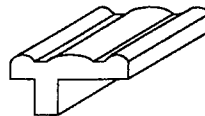

Front Door Molding

Part No. S-156
100"

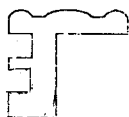

Moving Window Molding

Silver Foil Mirror
2 5/16" x 11 1/2"



ASSEMBLY INSTRUCTIONS:

WALL PANELS:

Wall panels do not come assembled in the kit. Follow instructions to assemble wall panels.

An important thing to keep in mind about the kit parts: They are made of wood. Wood shrinks and expands according to humidity. We have found that the siding is most sensitive to dimension changes due to humidity. All siding used in Dura-Craft miniature houses is made from the finest kiln dried Ponderosa Pine. However, as a result of humidity and assembly with a water base glue, some swelling will occur, causing slight dimension changes.

If there is a minor cracking problem there is a simple solution. A thick bead of glue should be run into the gap. Wipe off any excess glue and allow to dry. If necessary, repeat this step until the gap is filled. When the house is painted, there will be no evidence of the gap. Once walls are sealed with oil based sealer, latex paint can be used on siding. This will prevent walls from cracking.

1. Locate all Siding parts.
2. Pre-assemble the siding without glue. Connect the pieces, flat side down, as shown in Fig. 1. The tongue is on the top edge of each board.

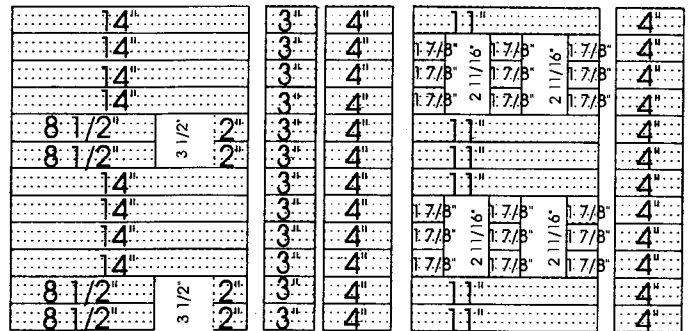

WALL A WALL B WALL C WALL D WALL E

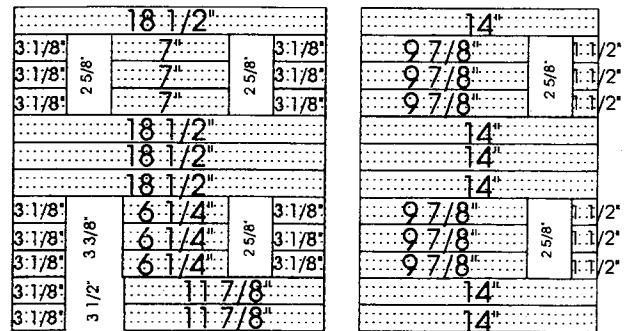

WALL F Figure 1 WALL G

3. Use the framing square to insure that the ends of the siding pieces are properly aligned. Note the intentional misalignment in the door opening.

4. Prepare an area for gluing. You will need a hard, flat surface at least three feet by four feet in size. Select a location where the wall panels will not have to be disturbed for several hours after gluing. Tape waxed paper over the entire surface.

5. Use the following technique for gluing the wall panels: Apply a thin bead of glue to the tongue then seat it in the groove. Immediately wipe off any surplus glue that squeezes out, using a damp-but not wet-cloth. Assemble the panels flat side down on the waxed paper. Make sure that all parts are arranged in the correct sequence. It is very important that outer edges of the walls are flush. If you don't have a square use a table corner.

6. Make sure that all joints are tight, and that edges of the walls are square and flush. Place weights on the panels as you finish them. Allow about an hour for the glue to set before moving or adding to the panels.

7. When wall panels are complete and have set for about an hour, stand them on edge to allow air to reach both sides. Let wall panels dry in a warm, dry place for at least 24 hours, preferably 48 hours. When walls are dry, seal with oil based sealer.

The next step is very important: Using the diagrams of the part sheets in the back of this booklet, label each individual part with a piece of masking tape. This way, after punching out all parts, you will be able to recognize what each piece is. If you lose the tape label, you can identify it by referencing it to the diagrams provided in the back. Make sure that the tape labels stay with each part until the final stages of assembly.

BRICK WORK:

1. Locate Base Walls (Sheets FH-17 and 20) and all Chimney parts (All on Sheet FH-25)
2. Splice Base Walls D and E together and G and H as in Fig. 2. Use waste pieces from the inside of frames on FH-3 to splice Base Walls D and E and Base Walls G and H together on the bad side. Glue and tape Base Walls together.

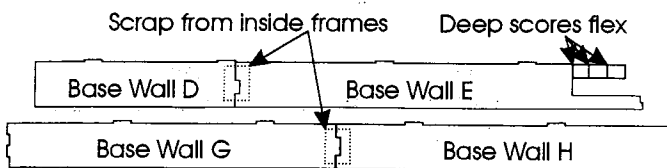

Figure 2

3. Assemble Chimney as shown in Fig. 3. Do not attach drip plates until after bricking. The 2 5/8" and 12 1/2" measurements match the 1st and 2nd floor heights.

4. Paint the Base Walls and Chimney with a latex paint.

This paint will become the mortar lines between the bricks. Black, white, and grey are popular. Let dry.

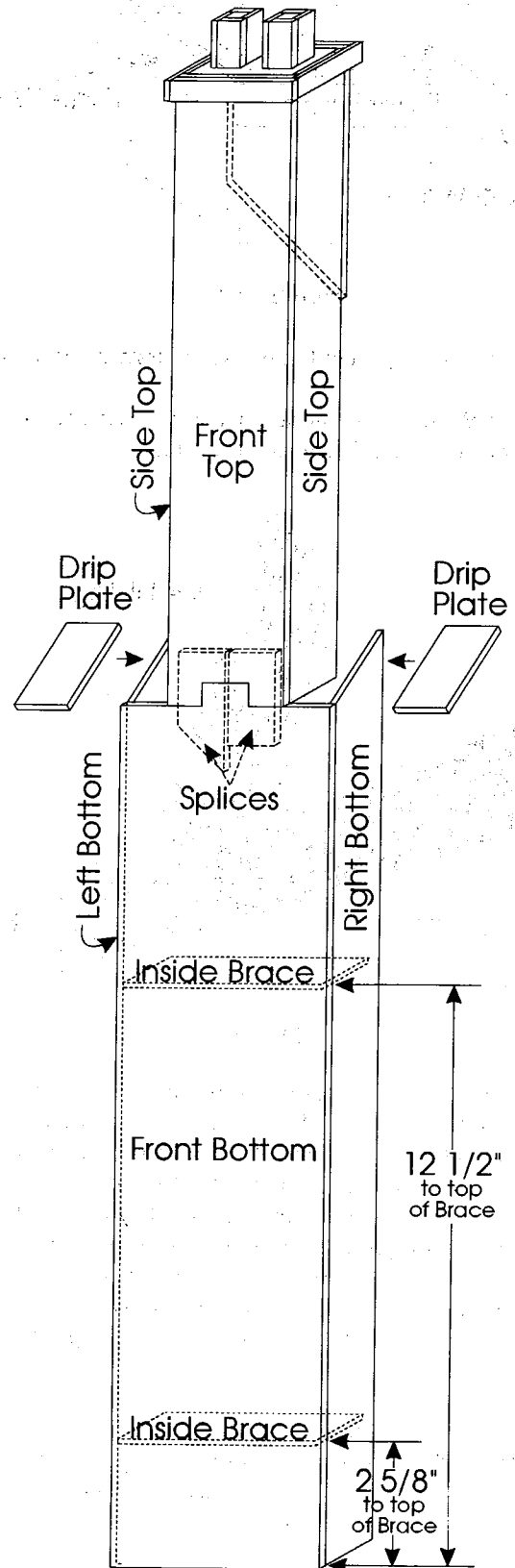

Figure 3

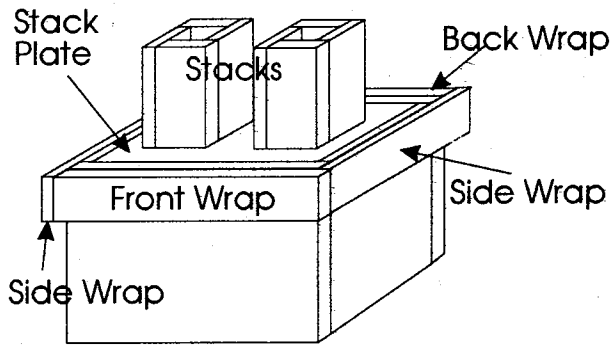

Figure 3 cont.

5. Peel the webbing from the Brickwork Pattern as in Fig.4.
6. Stick to Base Walls leaving enough overhang to hold on to for removal. Press firmly for full contact.

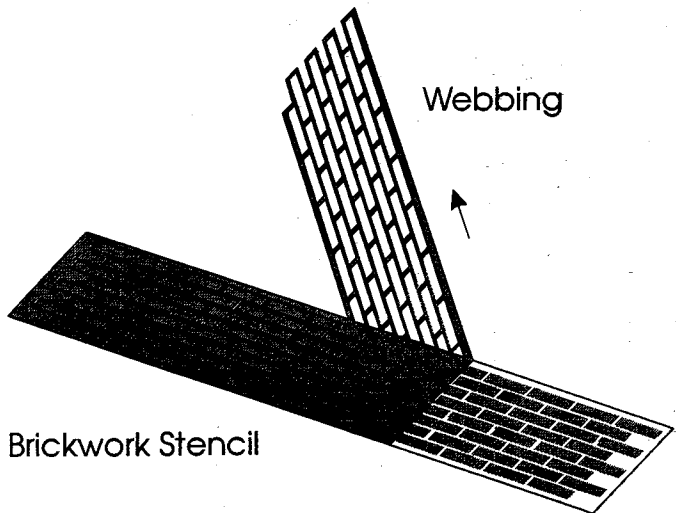

Figure 4

7. To cover 1 foot of brick template tape it takes 1 ounce or 1 1/4 tablespoons of brick powder. Put about 3 tablespoons of Tacky glue (or other white glue) into a cup, add about 1 1/2 tablespoons of water to the glue. Mix well. Put the appropriate amount of brick powder for the length of surface you are going to brick into a different cup. Slowly add small amounts of glue mixture to the brick powder (It is easy to add too much glue mixture). Mix after each addition. Continue until mixture starts to hold its own shape like cake frosting.

8. Spread brick mix over webbing with a putty knife to about 1/16" thick. If you would like to paint the brick to change its color or to give it an aged look, then paint the brick now before the webbing is removed.

9. Remove webbing within 5 minutes. Stick the overhanging webbing to a piece of scrap wood and pull as you did when taking the webbing off of the backing. The

wood handle will help pull off the webbing evenly.

10. If needed, touch up the bricks with a small piece of wood while the bricks are still soft.

11. Repeat process for chimney. On the inside of the chimney, paint the top of both supports and 4" above black.

BASE:

1. Locate all Base Floor Parts (Sheets FH-1,2,3,4,17 and 18).

2. Position Base Floor A,B,C and D good side up and tape together. Fig. 5.

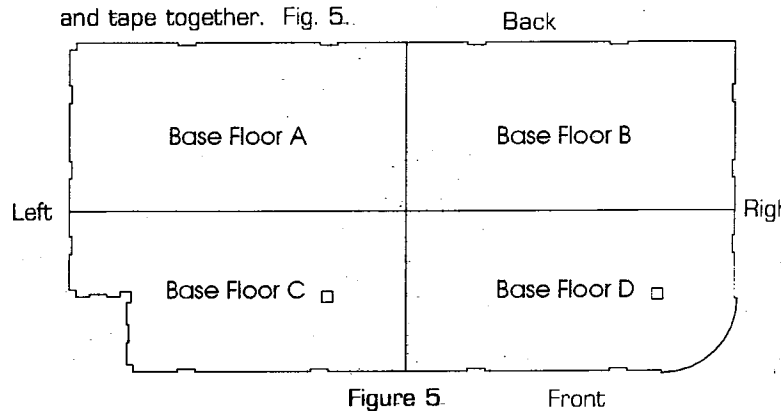

Figure 5

3. Turn Base Floor assembly over. Glue and tape Base Floor splices into position on bad side as illustrated in Fig.6. Allow to dry.

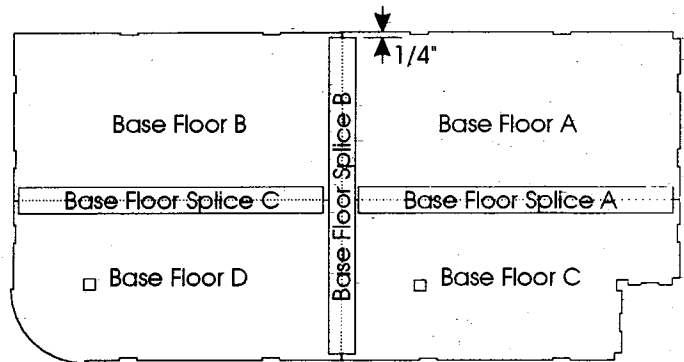

Figure 6

Note: Center splices on seams leaving at least 1/4" of space from splice to Base Floor Edge.

4. Assemble Base Floor Walls and Base Floor Supports as in Fig. 7. Glue and tape Base Floor Walls to Base Floor Assembly.

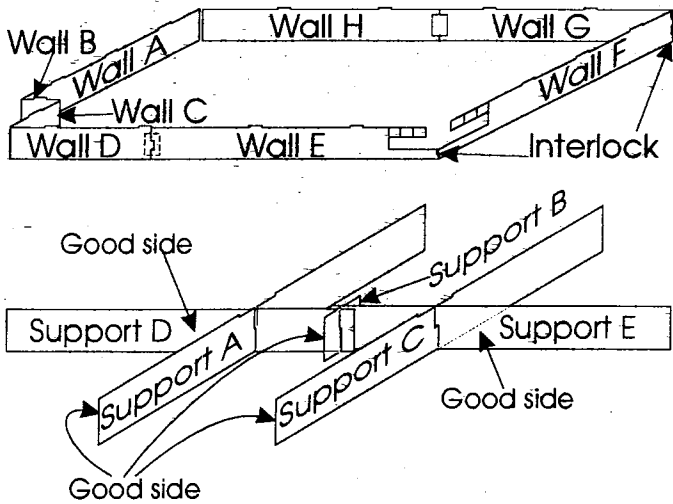

Figure 7

FRONT STEPS:

1. Locate all Front Step parts (Sheets FH-1,4 and 17).

IMPORTANT: When punching out Front Step Middle and Bottom Risers, Base Walls E and F and Corner Header, run a piece of 3/4" tape along the bad side of the deep scores so pieces will remain together.

2. With Base Floor upside down, tape together top risers and glue in place to form a smooth curve.
3. Install Front Step Middle Tread upside down with curved inside edge flush with top risers. Tape and glue into position.
4. Install Front Step Supports and tape into place.
5. Take Front Step Middle Riser; flex, tape and glue into position.
6. Install Bottom Tread and Riser same as Middle Tread and Riser. Fig. 8 shows an alternative assembly procedure.

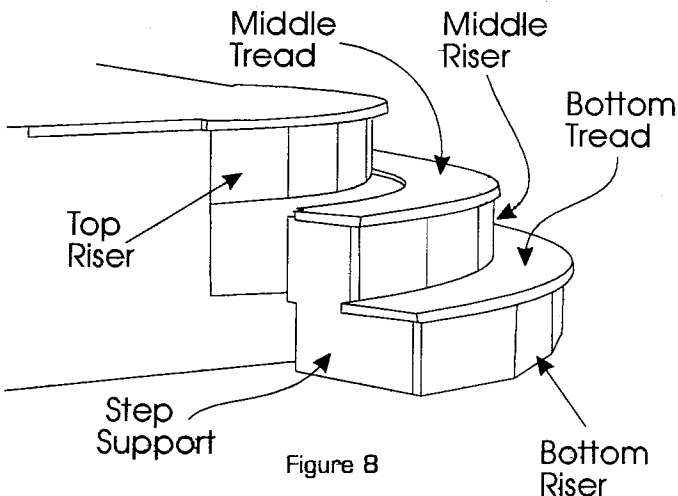

Figure 8

7. Paint steps after assembly.

HARDWOOD FLOORING:

The kit contains enough Hardwood Flooring strips to cover only one floor of the house. This material may alternatively be applied to the door, stairways, or used as wall paneling, but not all. Do not use water base glue for flooring as it will cause hardwood strips to curl. If you do not plan to apply the hardwood to the floor, skip this section.

1. Brush contact cement on the Base Floor and on one side of the hardwood strips. Follow instructions on the contact cement.

WARNING: Oil based contact cement is extremely volatile and flammable. The working area must be well ventilated. Keep away from flame or sparks. We suggest using neoprene based contact cement.

2. Start laying hardwood strips at the back of the house and work toward the front. Cut the strips with scissors. Off-set the joints as shown in Fig. 9.
3. After the hardwood strips are in place, burnish them down by rubbing them firmly with a small wood block.
4. To achieve a pegged appearance punch the ends of each strip with a 3/32" nail set. Fig. 9.

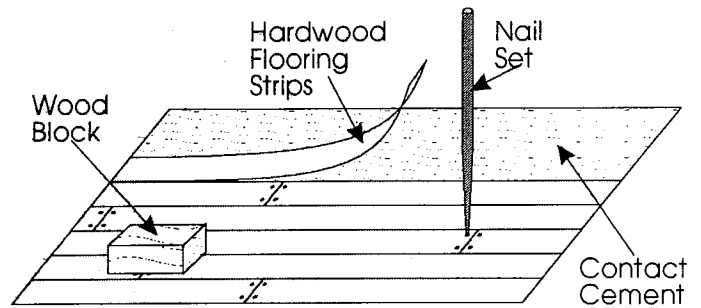

Figure 9

5. Sand the flooring smooth and remove any traces of contact cement that would interfere with the positioning of the walls on the base.
6. Using a knife, carefully cut the flooring away from covering the square hole in the floor. This is best done from the underside of the floor.
7. Varnish. To prevent varnish from dripping over the Base onto the brickwork, tape paper around entire Base Floor.

DIEBOARD PARTS:

1. Punch each individual piece out of its sheet and group accordingly into large baggies, i.e. all Staircase Supports,

Risers and Treads in same bag.

2. Sand each part.

ROOF:

1. Locate all Roof and Dormer Roof parts (Sheets FH-5,8,9,15,16,17,18,19 and 22)
2. Assemble Front Roof A and B, good side down, and glue. Place heavy object on interlocking junction until dry.
3. Assemble Back Roof A and B; glue together.
4. Assemble Porch Roof Front, Corner and Side; glue together.

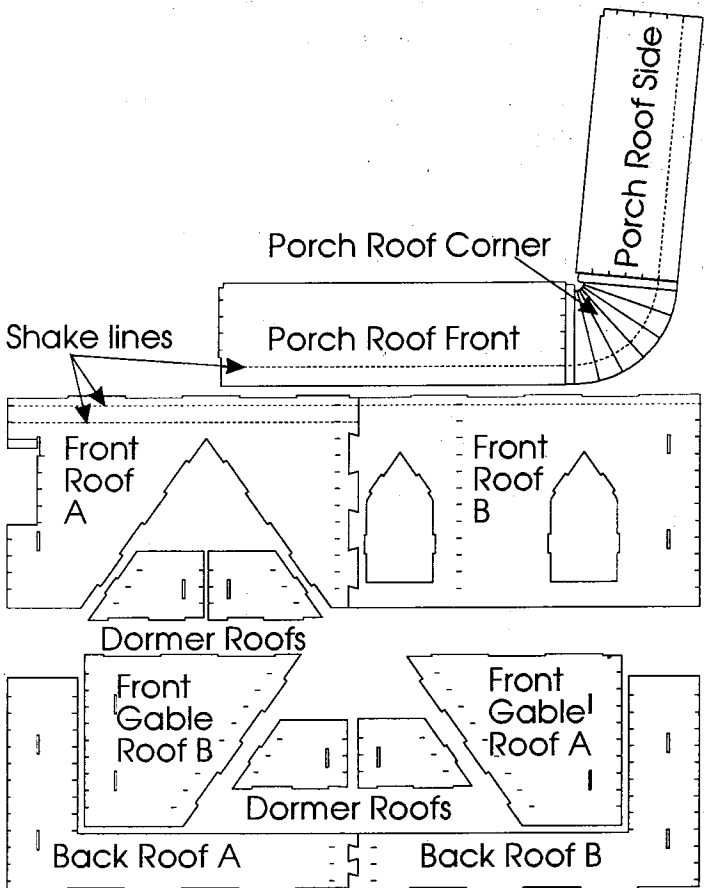

Figure 10

5. Find one of the light score marks on the edge of the roof. Using a straight edge and a pencil, connect it with the light score mark directly across forming a line parallel with the bottom edge. Continue this process with all score marks on each roof part. These are the shake lines. Fig. 10.

6. Paint the bad side of the Roof assemblies. This side will be inside the house.

2ND AND 3RD STORY FLOORS:

1. Locate 2nd and 3rd Story Floor parts (Sheets FH-5,6,7,8,9 and 10).
2. Tape 2nd floor parts A,B and C together, good side up, as in Fig. 11.

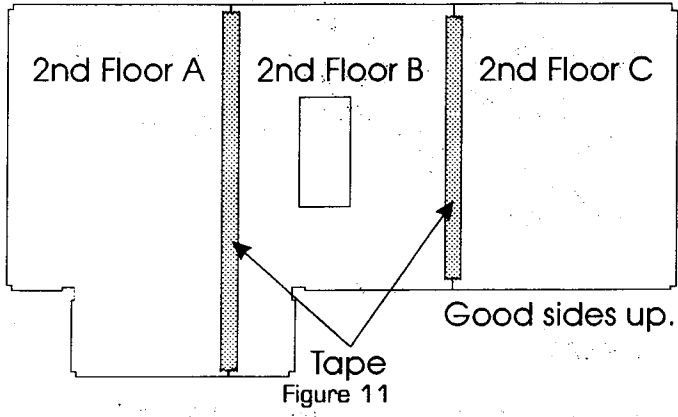

3. Turn floor over, run a bead of glue in the junction between floors. Splice together using 2nd Floor Left and Right splices. Be sure to center splices leaving 1/4" from edge of splice to edge of floor. Fig. 12.

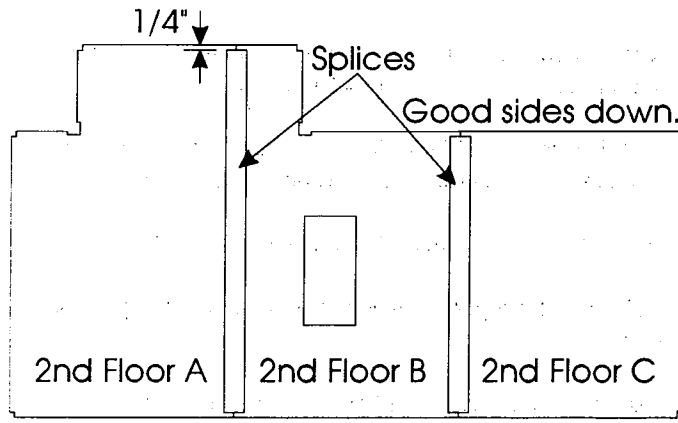

Figure 12

4. Repeat procedure using 3rd Floor assembly parts.
5. After glue has dried, paint the bad side of the 2nd and 3rd Floor assemblies. This is the ceiling side.

FIREPLACES AND HUTCH:

1. Locate Fireplace parts (Sheets FH-6 and 10), and Hutch parts (Sheets FH-11,12,13 and 14)
2. Assemble 1st Floor Fireplace as in Fig. 13.
3. Assemble 2nd Floor Fireplace as in Fig. 14.
4. Assemble Hutch as in Fig. 15.

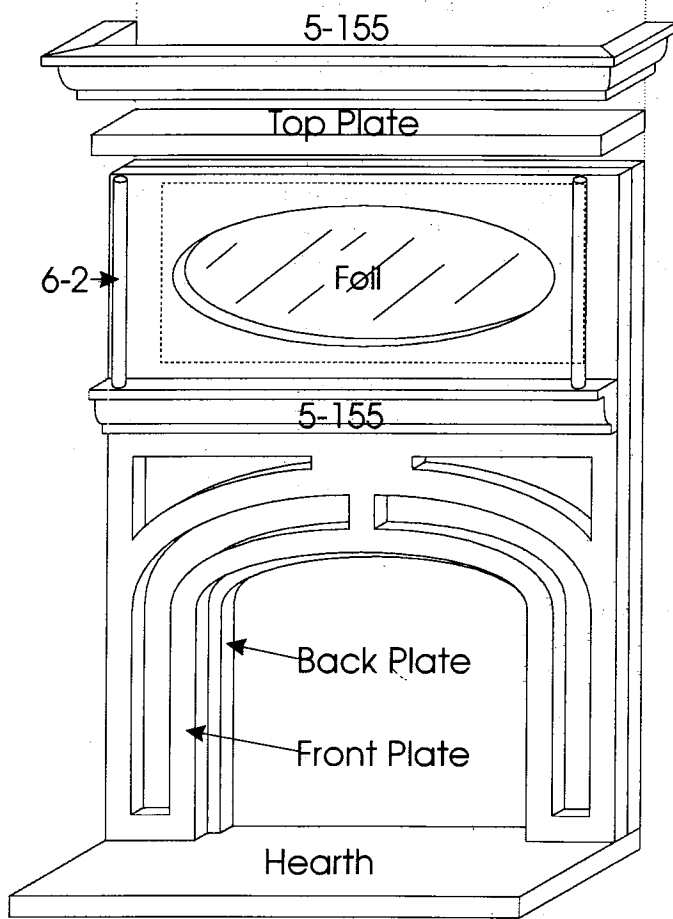

Figure 13

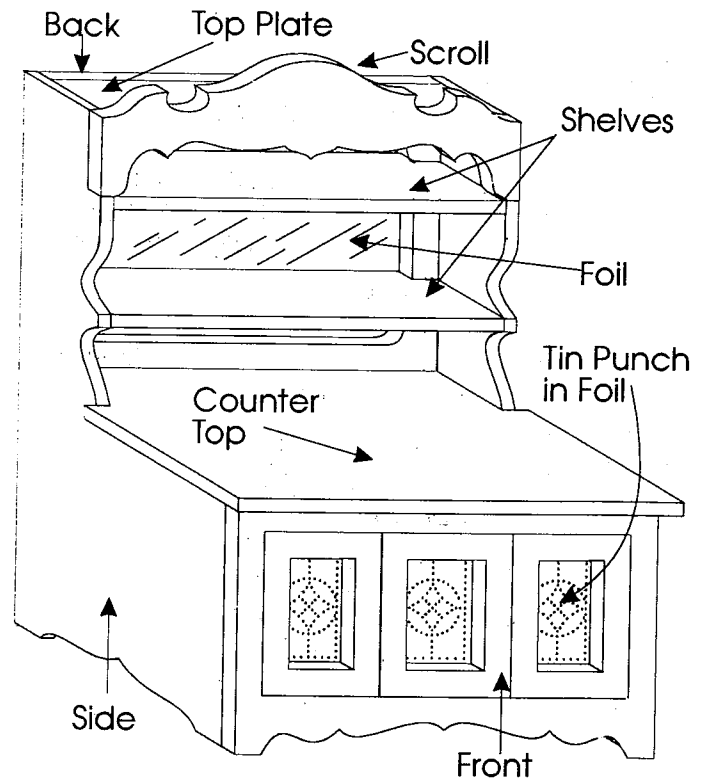

Figure 15

5. Cut out the Hutch tin punch pattern on the front inside cover of this manual. Tape to silver foil and punch out pattern using a small nail. Glue in place behind Hutch Door opening.

STAIRCASES:

1. Locate Staircase Supports, Risers, and Treads (Sheets FH-2,3,4,9,10,11,12,13,14,16,18, 20, 24, 26 and 28).

The Stair Treads and Risers are not all the same. The grain of the wood is either horizontal or vertical. If you are going to stain one set of stairs, make sure the grain on all Treads and Risers is going the same direction.

2. Set two Staircase Supports on the longest flat edge with the good side of both facing to the left. Tape all risers into position making sure that the edges are flush. Note that top and bottom risers are narrower than all other risers.

3. Risers go behind and under treads.

4. Tape treads into position leaving a 1/8" overhang on left edge and flush on right. Fig. 16.

5. Individually un-tape and glue each riser and tread into position.

6. If you are going to paint your staircases do so after the glue has dried.

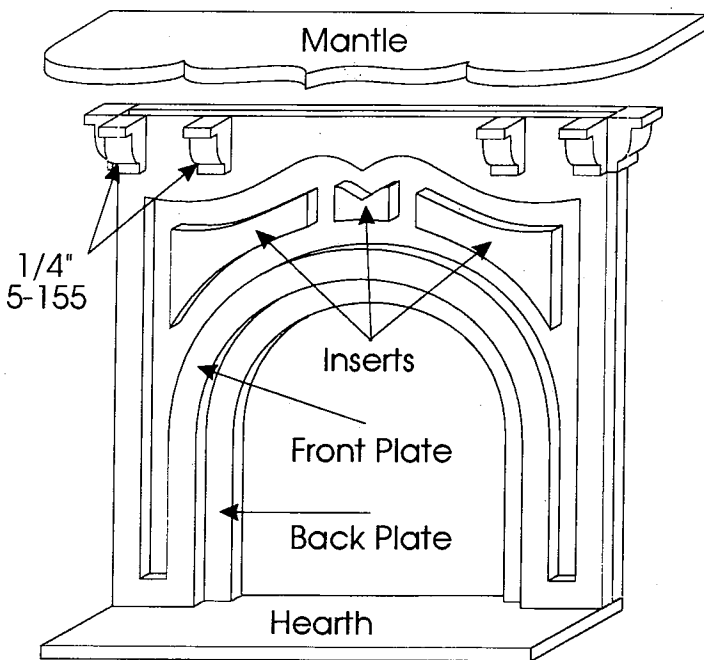

Figure 14

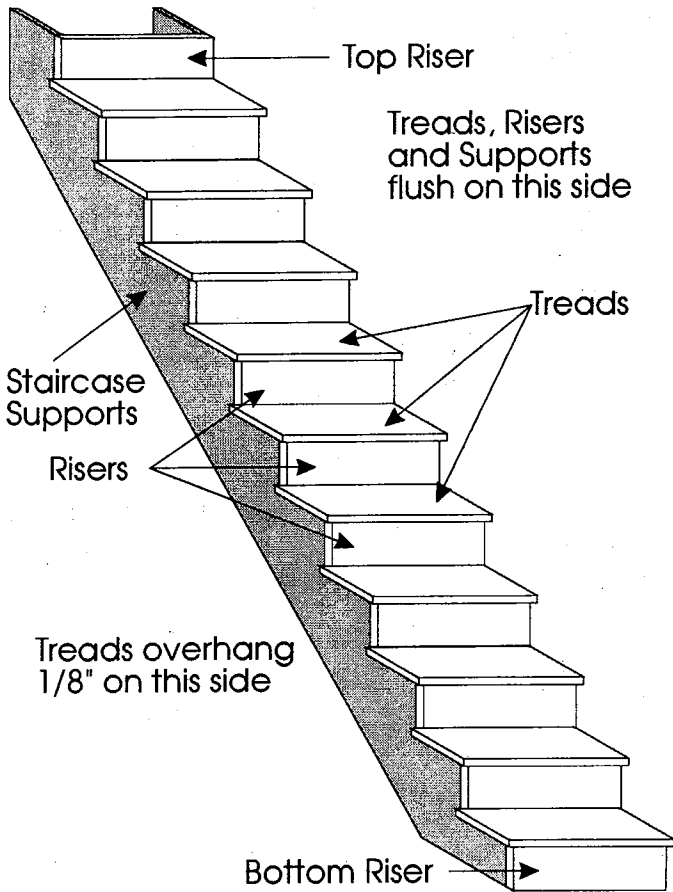

Figure 16

BACK ARCHES:

1. Locate all Back Arch parts (Sheets FH-21 and 27)
2. Assemble as in Fig. 17.

NOTE: 2nd floor back arches are slightly shorter than 1st floor back arches.

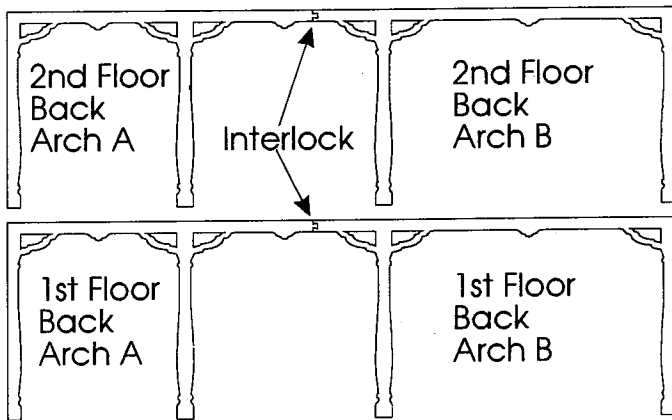

Figure 17

3. Paint Arches after glue has dried.

WALLS/GABLES/3RD STORY WALLS:

1. Locate all Gable and 3rd Story Wall parts (Sheets 22,23 and 24).
2. From the bottom edge of one gable, measure up $3 \frac{1}{8}$ " and draw a straight line parallel to the bottom edge of the gable. From this line draw lines every $\frac{3}{4}$ " all the way to the top. These are shake lines. Fig. 18.
3. Repeat this process for all gables.
4. Next you need to shake the Right and Front Gables only. Due to placement of the chimney the Left Gable will be shaken later. Using plain shakes, glue one row of shakes making the top edge of the shakes flush with the bottom line.
5. Now using fancy shakes, glue shakes to the rest of the gable working from the bottom up. Let the shakes overhang the gable edge. After allowing glue to completely dry, you can carefully cut the shakes so they are flush with the gable edge. Cut from the bottom up.

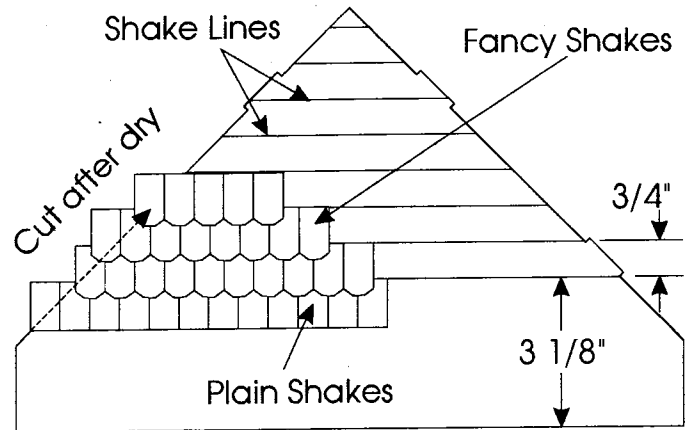

Figure 18

6. Lay Siding Walls A, D and G flat side down on your working surface. Glue Left Gable, Front Gable and Right Gable, good side up, to Walls A, D and G respectively. Make sure flat sides and bad sides are flush.
7. Now lay walls B, C, E and F flat side down. Glue 3rd Floor Walls B, C, E and F to appropriate walls. Make sure edges are flush and flat and bad sides are flush.
8. Paint Walls, Gables and 3rd Floor Walls to desired color but do not paint over shake lines on left gable.

FLOOR SUPPORTS:

1. After walls and gables are dry, lay one of the assembled walls flat side up on the working surface.
2. Using a pencil and a ruler, measure up from the bottom

edge 9 3/4" and draw a line parallel to the bottom edge.

3. From the line you just created, measure up 9 7/8" and draw another line. These mark where your 2nd and 3rd Story Floors will be seated.

4. Cut two pieces of your 1/4" x 1/4" molding making them 1/2" shorter than the width of the wall you are currently working on.

5. Run a bead of glue on one side of the moldings and affix the top edge flush with the lines you drew. Center the 1/4"x1/4" molding so there is 1/4" of wall past the end of the molding on each side. See Fig. 19.

WALLPAPERING:

The next step in the construction of your miniature is to wallpaper the Walls and Room Partitions. Wallpapering gives a very nice finished touch to the house and adds to its uniqueness as well. Wallpapering for your miniature can be found in many craft and hobby stores. If you are not going to wallpaper, skip this section. If you are going to have electric working lights and wiring in your house, wallpaper after assembly and wiring.

Wall F is going to be split by a Room Partition on the 1st and 2nd floor creating four separate rooms. If you are going to wallpaper each room differently you must determine where the junction of the different paper types will occur. To determine this:

1. Lay Wall F flat side up on your working surface. Measure 8 13/16" from the left edge. Draw a line from the bottom to the top of the wall to show where the wallpaper junction will occur.

2. Before wallpapering, you need to identify the orientation of the room partitions. The 1st Floor Right Room Partition's doorway is on the back side of the house. All other Room Partition doorways are on the front side of the house. Make sure the Partitions stay labeled.

3. Now you can wallpaper. Pick a wall to paper and apply paste to entire surface. Put the paper on letting it overhang the edges. You can trim to size after it dries. Don't forget to paper the appropriate room partition also. The 1/4" x 1/4" molding can either be papered or left exposed and painted to act as trim. Do not paper the top edge of the 1/4"x1/4" molding. You might refer to the back view to get an idea of what each room will look like.

WINDOW FRAMES:

1. Locate all Window Frame and Slider parts (Sheets FH - 1,2,3,11,12,13,14,15,19,21,23,27 and 28) and Window Glass.

2. Punch out the middle of all Frames and Sliders. Paint the good sides and edges

NOTE: Half of the window frames get clear glass, half get glass with the silkscreen pattern. When inserting the patterned glass make sure the silkscreened side is facing the same direction as the frame.

3. Lay a Slider good side down and place a piece of glass on it.

4. Run a bead of glue around the bad side of the Frame and center it on top of the glass and Slider. Make sure glue adheres to both glass and wood.

Insides of walls

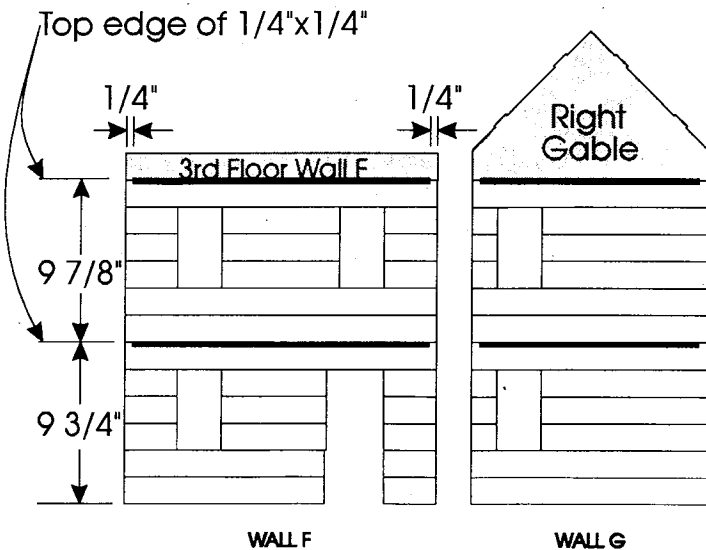
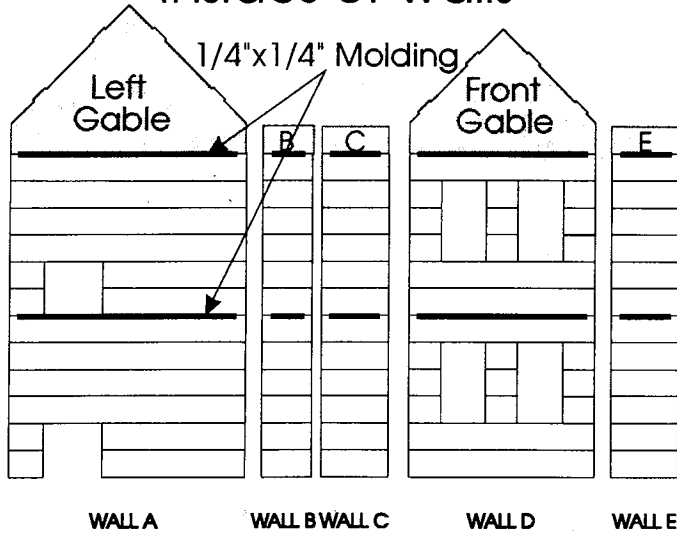

Figure 19

6. Continue this process for all walls.

5. Continue this process for all Frame and Slider parts.

CARPET:

If you have decided to carpet your miniature, this would be the best time to do so. Locate the floors you would like to cover and select the fabric you wish to use as carpeting.

NOTE: One method we have found to be quick and easy is to use spray adhesive. When using the spray adhesive make sure you are in a well ventilated area.

1. Completely cover the good side of one of the floors with the spray adhesive.
2. Do not cut your carpeting before applying it to the floor. Lay the whole piece of fabric on the floor you are carpeting and be sure to let it overhang the edges.
3. After adhesive has dried, cut the excess amount off leaving about a 1/8" overhang. This will compensate for any gaps that may form during construction.
4. Repeat this process for all floors you wish to carpet.

LONGFRAME:

"Longframe" refers to the long pieces of wood used for gutters, corner posts, molding, etc. Take this time to paint all Longframe to your specifications.

WALLS AND CORNER POSTS:

1. Cut large corner posts to 25" long (part 5-2). Insert into holes in Base Floor assembly as in Figure 20.
2. When installing walls, run a bead of glue in the grooves of the posts then fit walls into the grooves. Glue the bottom of the walls to the floor. Wipe off any excess glue. Fully seat walls into grooves. It may help to lightly sand the edges of the walls to a slight taper so the walls fit fully into the grooves.
3. Insert walls into appropriate grooves as shown in Figure 20. Let dry.

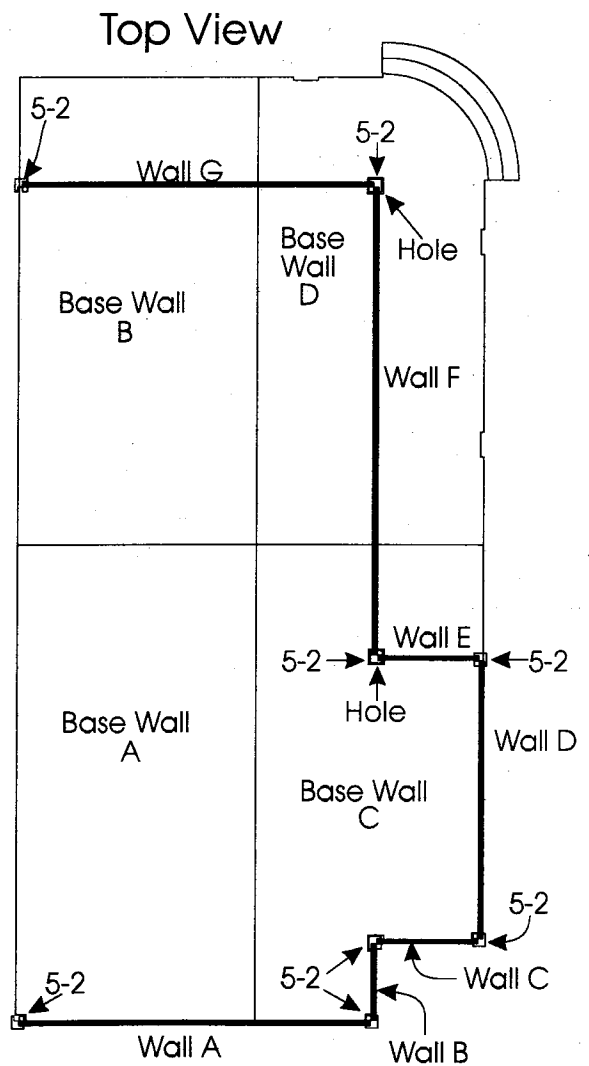

Figure 20

4. Using the Anchors (Sheets FH - 17 and 20) you now need to anchor your Walls and Corner Posts. Run a bead of glue in the grooves of the Corner Posts on the underside of the Base Floor. Insert one anchor piece into each groove and glue to base floor. Fig. 21.

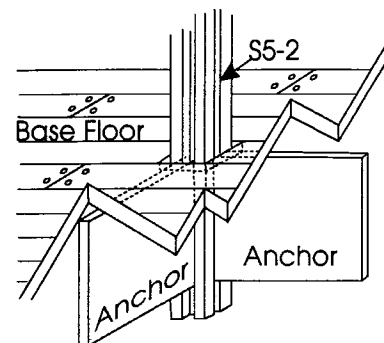

Figure 21

WINDOW INSTALLATION:

1. Cut these pieces of Longframe to the specified lengths:

| Part: | Quantity: | Length: |
|-------|-----------|------------|
| 5-156 | 18 | 4 3/4" |
| 5-155 | 18 | 3 3/4" |
| 5-3 | 18 | 4 7/8" |
| 5-155 | 18 | Template A |

Template A

2. Locate two window assemblies, one with silkscreen and one without, and two 4 3/4" length Moving Window Moldings (part 5-156).

3. Place the clear window assembly in the inside slot of the molding and tape into position with bottom edges flush. Place silkscreened window in the outside slot and tape into position with top edges flush. Fig. 22.

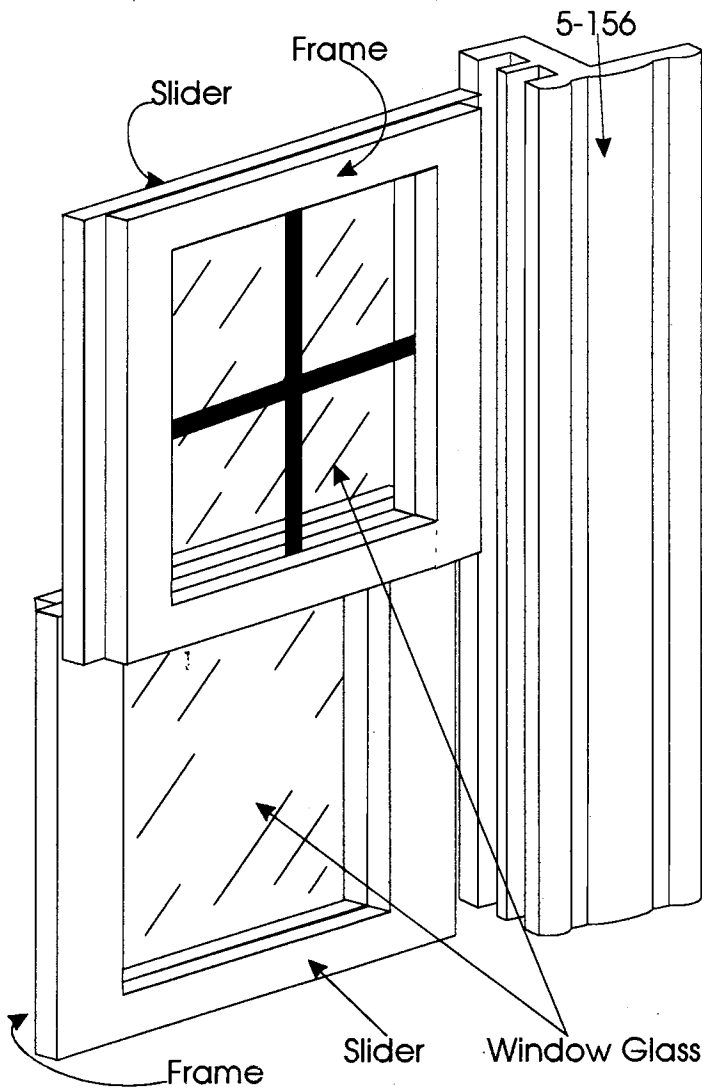

Figure 22

4. Dry fit entire assembly into a window opening in one of the walls. Glue into position.

5. Glue your pre-cut pieces of part 5-155 into position inside and outside of your window assembly. Glue pieces of part 5-3 into position on either side of the window on the inside. See label photo.

6. Continue this process for all windows. There should be two silkscreened window assemblies left over after all windows are installed. These are Dormer windows to be installed later.

DOOR ASSEMBLY AND INSTALLATION:

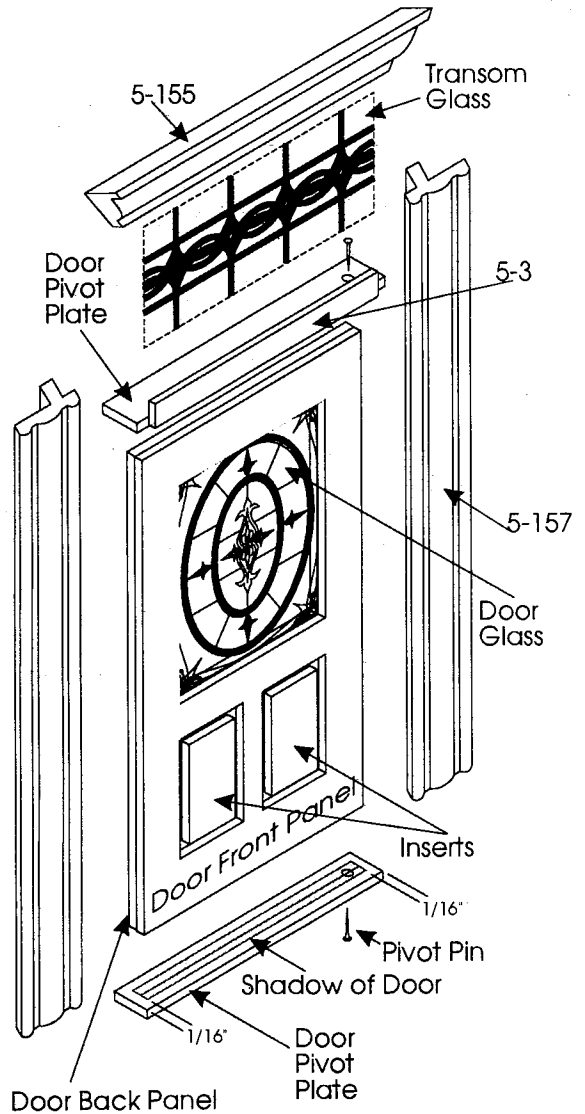

Figure 23

1. Cut these pieces of Longframe to the specified lengths:

| Part: | Quantity: | Length: |
|-------|-----------|------------|
| 5-157 | 2 | 8 1/8" |
| 5-3 | 1 | 3 15/16" |
| 5-155 | 2 | Template B |

Template B

Floor Room Partition doors.

2. Locate all Front Door parts (Sheets FH - 5 and 8) and Front Door Glass.
3. Assemble door as shown in Figure 23.
4. Slide door assembly into position and glue in place.

BACK ARCHES/FLOORS/ROOM PARTITIONS:

1. Cut these pieces of Longframe to the specified lengths:

| Part: | Quantity: | Length: |
|-------|-----------|------------|
| S5-2 | 2 | 32 5/8" |
| 5-70 | 8 | 7" |
| 5-155 | 6 | Template A |
| 5-155 | 2 | Template C |

Template C

1. Run a bead of glue in the grooves of the back Corner Posts (5-2) and slide Back Arches into position. Glue part S5-2 into position on top of the Back Arches with open groove towards front of house.
2. For identification purposes, two Room Partitions have been notched at inappropriate widths. The 1st Floor Left Room Partition notch needs to be widened from 1/8" to 1/4". And the door side notch of the 2nd Floor Right Room Partition must be widened from 1/8" to 1/4" also.
3. Before installing the Room Partitions you need to apply trimming to the door. To do so use part 5-70 and 5-155. The cropped pieces of part 5-155 belong under the staircase.
4. Now install 1st Floor Room Partitions. Viewing the house from the front, the 1st Floor Right Room partition's door is to the back of the house. All the other room partitions have doors to the front. Glue Room Partitions into place on all edges. Room partitions should be centered on the Back Arch Posts. The Left Room Partition should be flush with the stairwell opening.
5. Run a bead of glue along the top of the 1/4"x1/4" floor support molding and in the remaining groove of part S5-2 on top of the Back Arch. Insert the back edge of the 2nd Floor assembly in the groove and firmly press the front edge down until it touches the floor supports. Wipe away any excess glue. Add weight to hold floor in full contact with supports.
6. Repeat the above process for installation of the 2nd Floor Back Arches, Corner Post S5-2, 2nd Floor Room Partitions and 3rd Floor. Note the placement of the 2nd

CUTTING CORNERPOSTS:

1. Using a small saw you now need to cut angles on the cornerposts to match the slope of the gables. Use the slope of the gables to assist you in cutting a 45 degree angle.
2. The corner posts that connect Walls B and C and Walls E and F need to be cut at the same angle in two directions. Figure 24.

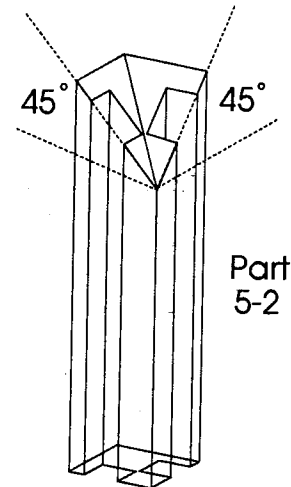

Figure 24

DORMER/GABLE ROOF ASSEMBLY:

1. Cut these pieces of Longframe to the specified lengths:

| Part: | Quantity: | Length: |
|-------|-----------|------------|
| 5-3 | 4 | 2 1/8" |
| 5-157 | 4 | 2 1/8" |
| 5-155 | 4 | 2 3/4" |
| 5-155 | 4 | Template D |

Template D

2. Locate all Dormer parts (Sheets FH - 5, 7, 8, 9, 16 and 24).
3. Assemble the Dormers as in Fig. 25.
4. Glue and tape the Dormers into position on the Front Roof assembly.
5. Paint Dormers to desired color.
6. Dry fit two pieces of part 5-157 into position in the Dormer Window opening. Slide silkscreened window assembly between the wall and part 5-157 and glue in place. Trim the window, inside and out, with the cut longframe.

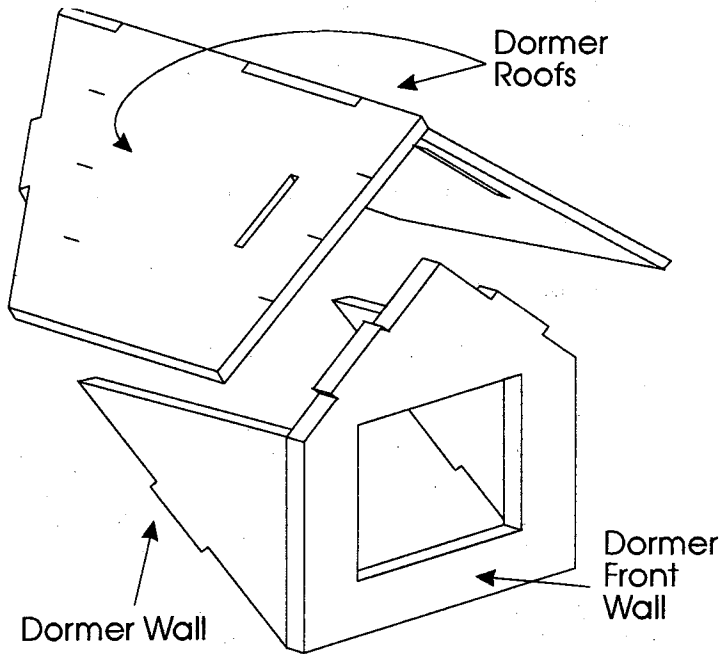

Figure 25

7. Locate the Front Gable Roof parts A and B (Sheet FH - 22).

8. Glue and tape Gable Roof A and Gable Roof B together, by interlocking the notches along the top edges. Insert into notches on the Front Roof assembly, glue and tape in place.

ROOF INSTALLATION/ROOM PARTITION:

1. Run a bead of glue along the Gable edges and the top edge of the 3rd Floor Walls. Tape Front Roof assembly into position with Gable Notches fitting into Roof Slots. Wipe away excess glue.

2. Run a bead of glue along the Gable back edges and along the Front Roof top edge. Set Back Roof assembly into position with Gable Notches fitting into Roof Slots and Front and Back Roof Notches interlocking.

3. Locate the 3rd Floor Room Partition (Sheet FH -7)

4. Glue the 3rd Floor Room Partition into position making sure the bottom edge is flush with the edge of the stairwell. 3rd Floor Room Partition is placed directly above the 1st and 2nd Floor Left Room Partitions.

STAIRCASE INSTALLATION:

1. Locate one of the staircase assemblies.

2. Run a bead of glue the length of the right Staircase

Support and along the top edge of the top riser.

3. When installing staircases, treat 2nd and 3rd floor opening ledges as treads. Insert the staircase making the 2nd and 3rd floor ledgs overhang the top risers 1/8". Glue and tape into position.

FIREPLACE INSTALLATION:

1. Run beads of glue over the back side of the 1st Floor Fireplace. Glue into position on 1st floor over the hole on Wall A. Wipe off any excess glue.

2. Repeat this process for installation of 2nd Floor Fireplace.

CHIMNEY INSTALLATION:

1. Locate your completely assembled chimney.

2. Run a bead of glue along the back edge of the chimney. Make sure the chimney is straight up and down and tape into position until dry.

PORCH:

1. Locate all Porch parts (Sheets FH - 9, 23, 26 and 28).

2. Lay Porch Front Arch, Porch Side Arch and Porch Corner Header face down, glue and tape together.

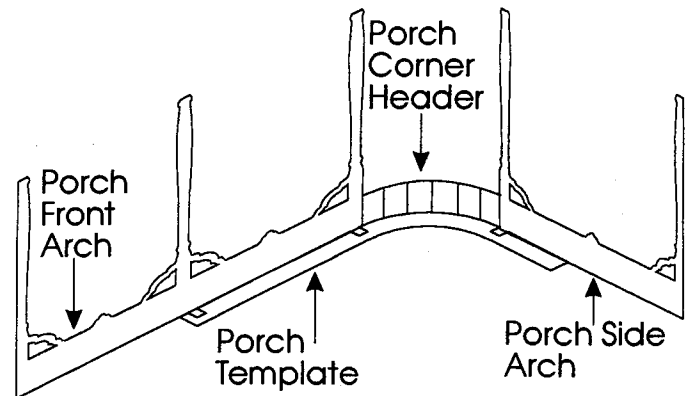

Figure 26

3. Set the assembly on edge with the posts pointed up. Tape the Porch Template into position with the 1/2"x1/2" notches centered on the Porch Front Arch Posts. Bend the porch corner around the template curve and tape to Porch Side Arch. Glue entire assembly together. Fig.26.

4. Locate your Porch Posts (part 5-37). Insert one end into a Porch Template notch and glue to the Porch Arch

Post. Glue all three posts into position.

5. Paint entire assembly

6. Trim the Base Floor edge before gluing the Porch Arch into position. Trim with part 5-3.

7. After the trim is in place, set Porch Arches into position. Glue left edge to the corner post. Glue the arch posts to floor flush with the edge of the flooring, not the edge of the trim. See label.

8. Glue and tape the Porch Back Arch into position on the inside of the Porch Arch, make sure edges are flush. Glue to corner post. See back view picture in manual.

8. Glue Porch Corner Brackets into position above steps. Refer to box picture for positioning.

RAILING:

1. Cut two pieces of part 6-4 to fit between two Porch Posts. This is the Lower Railing.

2. Glue Large Dowels (part 6-6) to Lower Railing. Glue the Dowels 1" apart from center to center.

3. Glue the second railing to the top of the dowels.

4. Continue this process for other porch sections. Paint railing after assembly is completed. Glue in place. See label.

PORCH ROOF:

1. Cut a piece of part 5-24 to fit between the Corner Posts on Wall G and glue under the ridge 11 1/4" from bottom of the wall on the outside of the siding. Glue so the long taper of the piece slopes down. Cut and glue another piece for Wall F at the same height.

2. After the roof support has dried, run a bead of glue along it and along the top edge of the Porch Arch.

3. Locate your Porch Roof assembly. Run a bead of glue along the back edge. Set into position on top of the Porch Arch. Align so the right side of the Porch Roof is flush with the Porch Back Arch. If a gap is created on the left side, it can be covered with shakes. Wipe away excess glue.

SHAKES:

1. Using the shake lines on the roofs as guidelines, you now need to shake the Front, Back and Porch Roofs and the Left Gable. Start from the bottom and work up.

2. On the Left gable, be sure to use only one row of Plain

Shakes and use Fancy Shakes on the rest.

3. When going around the corner on the porch roof, you will need to cut the shakes in wedge shapes to fit. Refer to the picture on the box for assistance.

4. After the glue has dried, trim the shakes flush with the side roof edges.

GABLE DECORATIONS:

1. Locate all Gable Deco. parts (Sheets FH - 7, 15, 22, 24 and 26)

2. Glue Gable Deco. Bottoms to Gable Decos. These also act as end caps for your gutters.

3. Paint Gable Decorations before glueing to roof.

4. Run a bead of glue along a gable edge and affix appropriate Gable Decoration. Let the top edge stick up above the shakes.

BANISTERS:

1. Locate the Small Dowels (part 6-2).

2. Glue one dowel on each tread.

3. Cut a piece of part 5-70 to fit as a railing. The top end should be glued to the ceiling. Glue into position.

4. Cut a piece of part 5-70 to fit the length of the right side of the 2nd Floor Stairwell. Glue flat side down.

5. Glue Small Dowels into position for railing. Cut a piece of part 5-70 to fit on top of the dowels and glue into position.

6. Follow the same procedure for the 3rd Floor Banister. It should encompass the right, back and part of the left sides of the stairwell. Fig. 27.

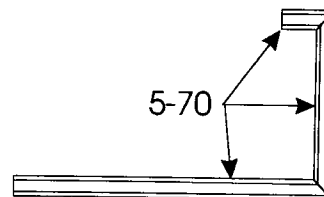

Figure 27

TRIM:

1. To add finishing touches to your nearly completed house, cut pieces of part 5-3 to fit in various places. Use it to trim the inside edges of the Dormer openings, for the Gable

opening, on the inside of the Front Roof and as base boards at the bottom of all walls on each floor.

GUTTERS AND DOWNSPOUTS:

1. Locate Gutter Longframe (part 5-142) and Downspout Longframe (part 5-143).

2. Cut the Gutters to fit on all Front Roof sections and on the Porch Roof Front and Side. See picture for assistance. Where Gutters come together at the Front Roof and Front Gable junctions, you can cut them at a 45 degree angle to fit together. Use scrap flooring for gutter caps if desired.

3. Downspouts are cut to fit as well. There are four Downspouts: One at the junction of Walls B and C, at the junction of Walls E and F, and on either side of the front steps on the Porch Arch Posts. For assistance, refer to front view photo.

CONGRATULATIONS!! You should now be finished with your Dura-Craft miniature mansion dollhouse! Take this time to look over your house for any loose ends. While you still have your tools and paint handy, fix any pieces that need fixing and use your paint for any touch up that needs to be done. After everything is done, display your house with pride and brag to your friends about how easy it was.

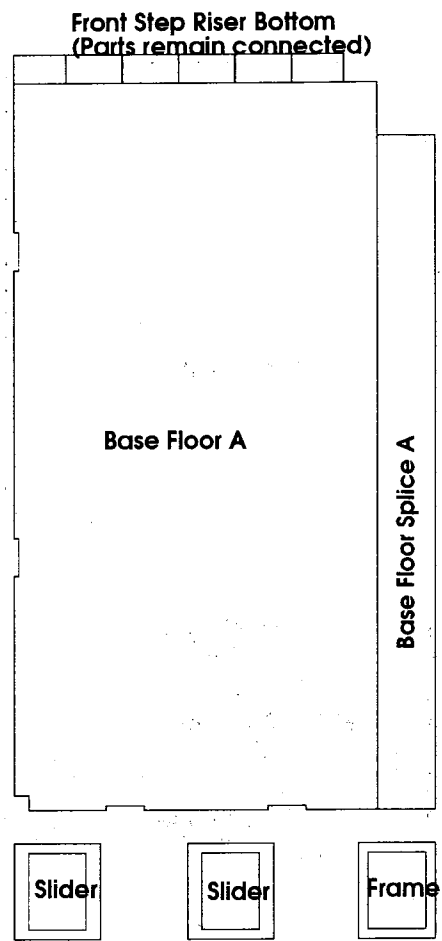

Sheet FH-1

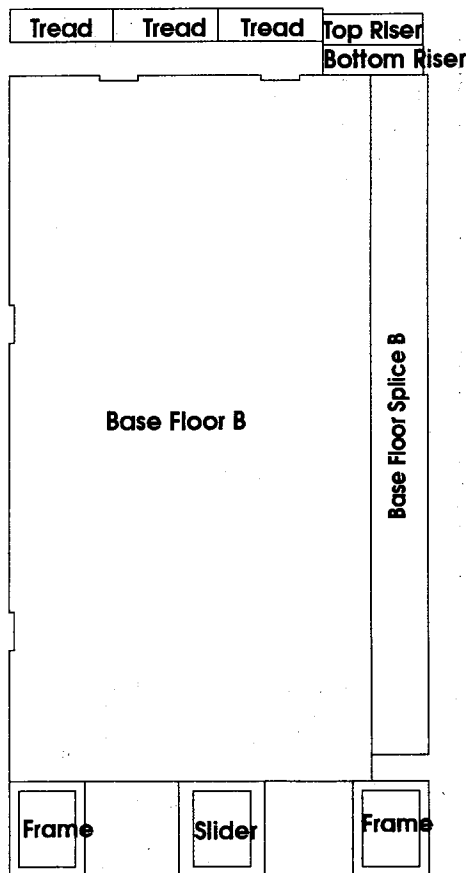

Sheet FH-2

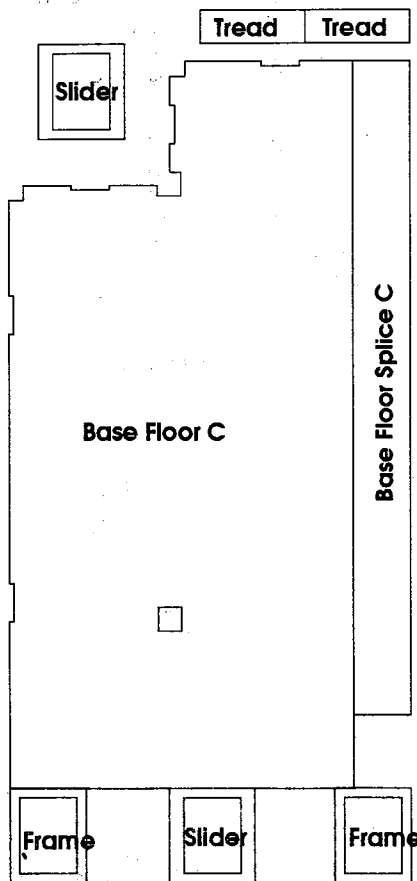

Sheet FH-3

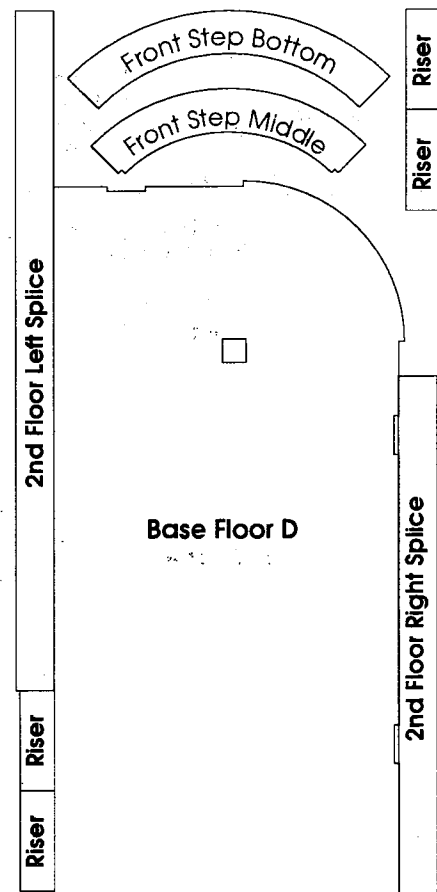

Sheet FH-4

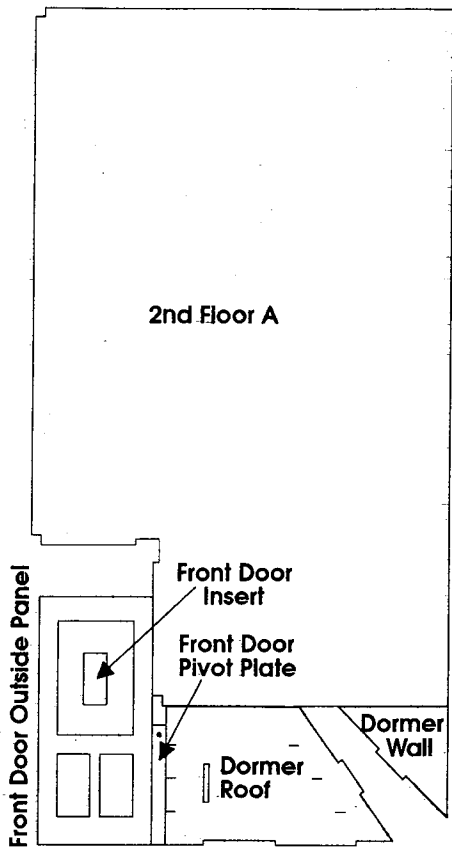

Sheet FH-5

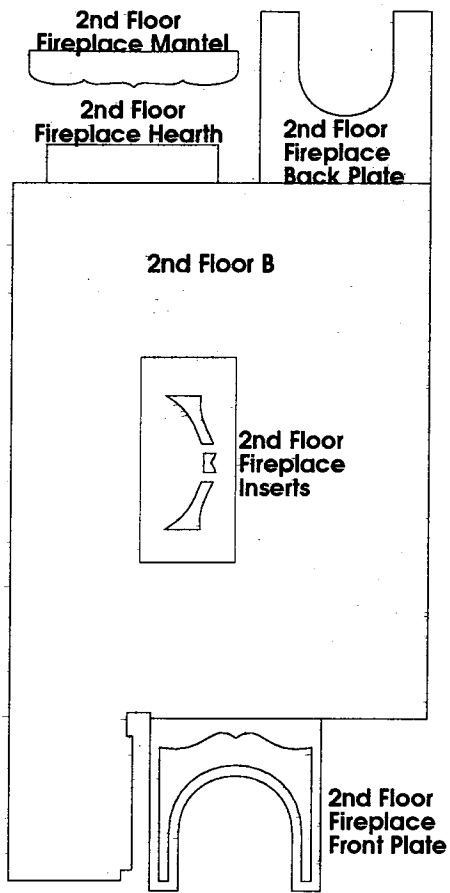

Sheet FH-6

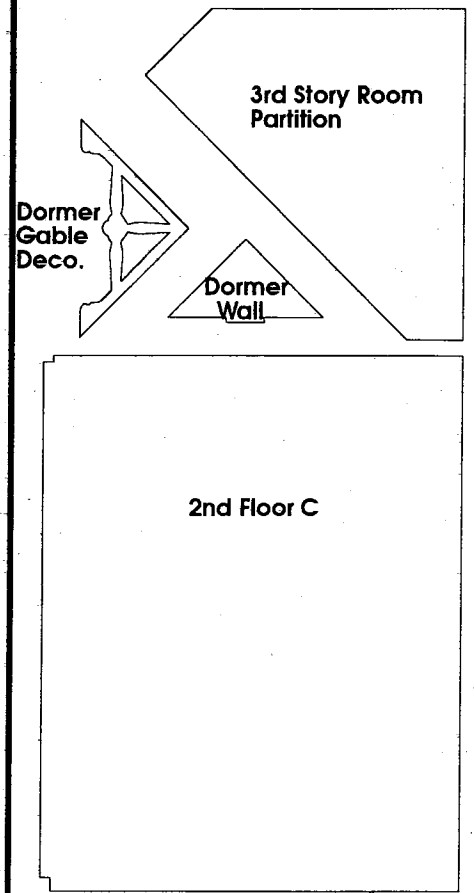

Sheet FH-7

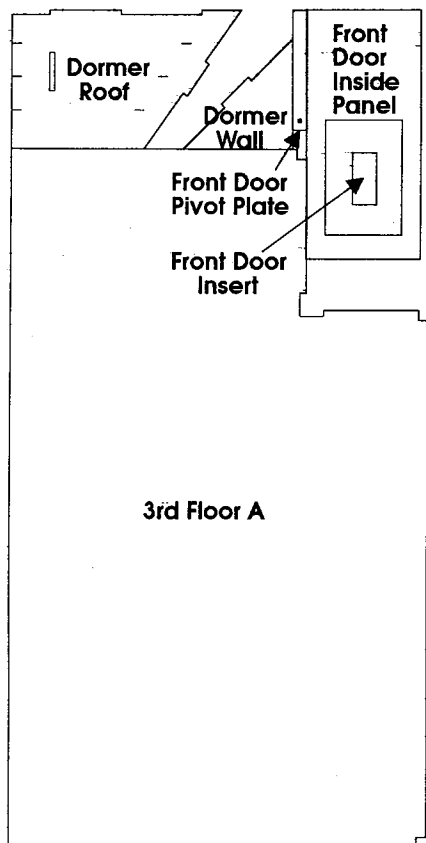

Sheet FH-8

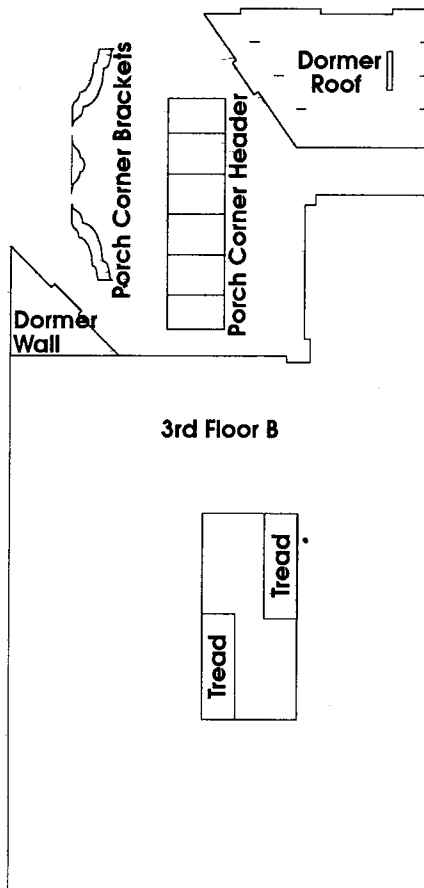

Sheet FH-9

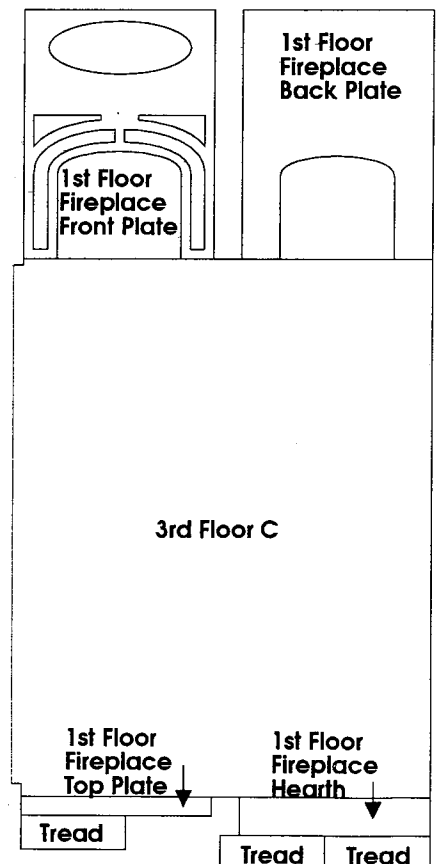

Sheet FH-10

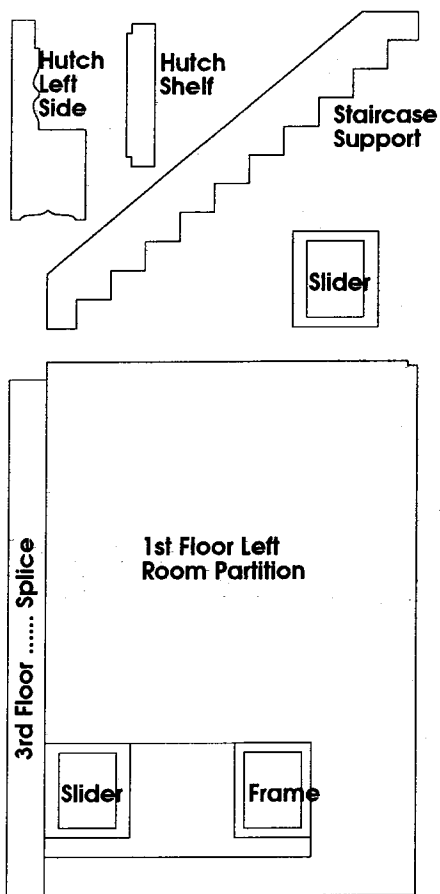

Sheet FH-11

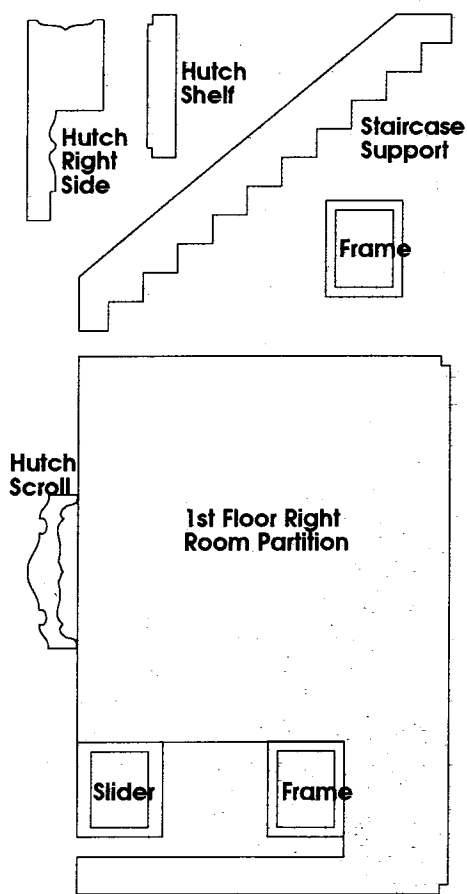

Sheet FH-12

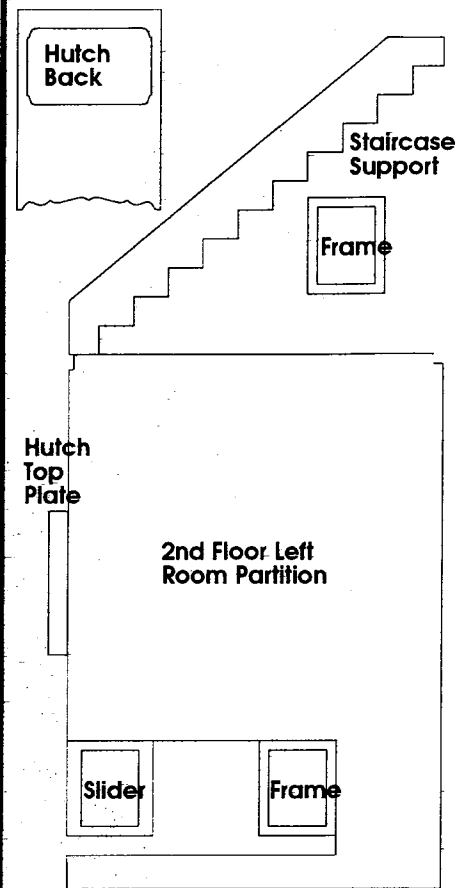

Sheet FH-13

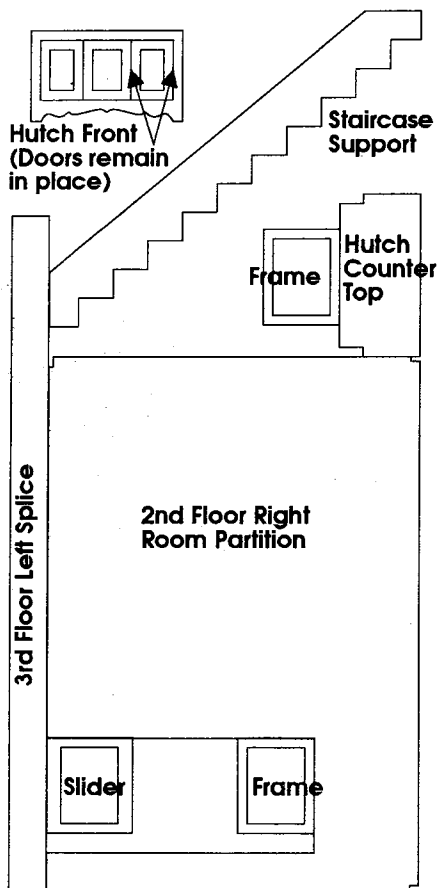

Sheet FH-14

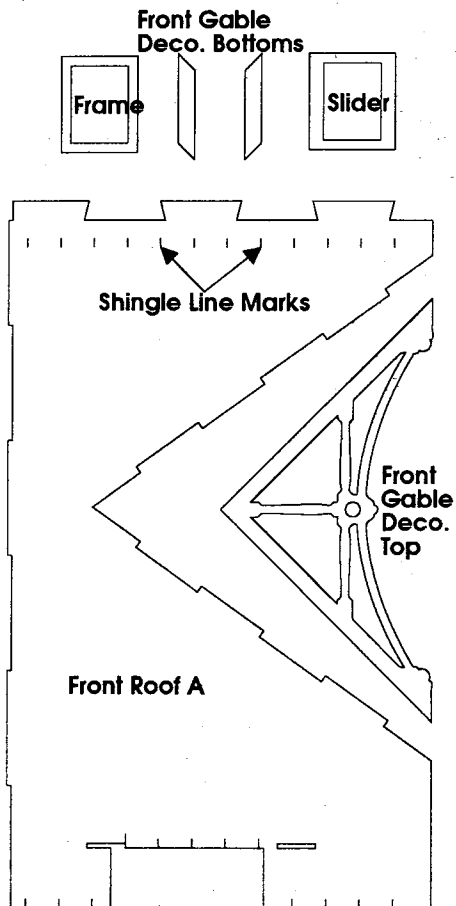

Sheet FH-15

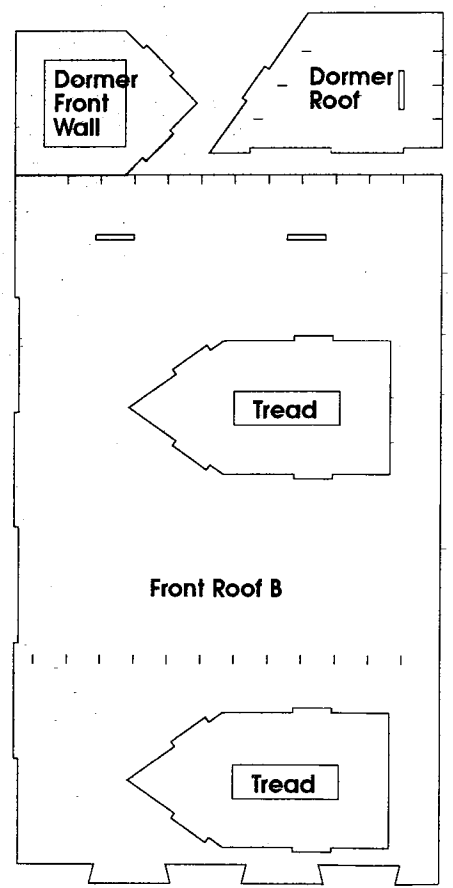

Sheet FH-16

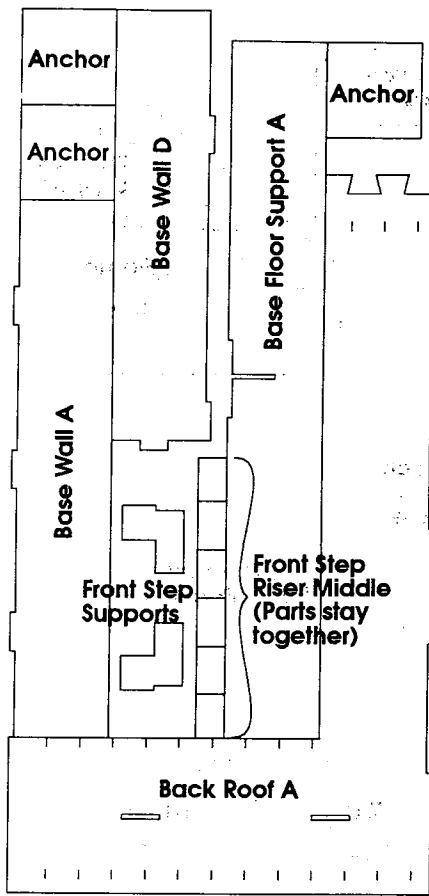

Sheet FH-17

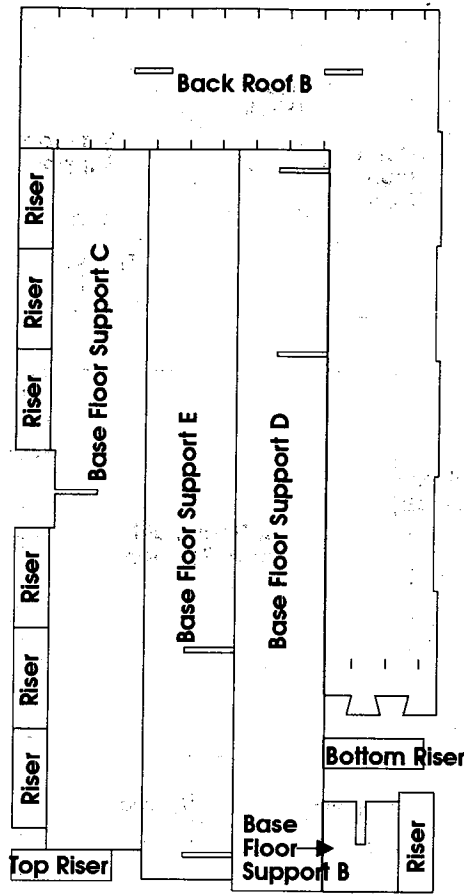

Sheet FH-18

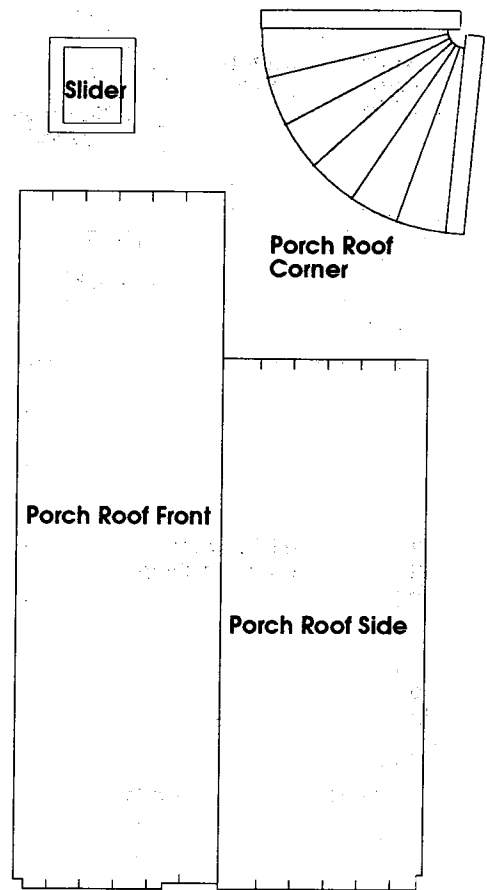

Sheet FH-19

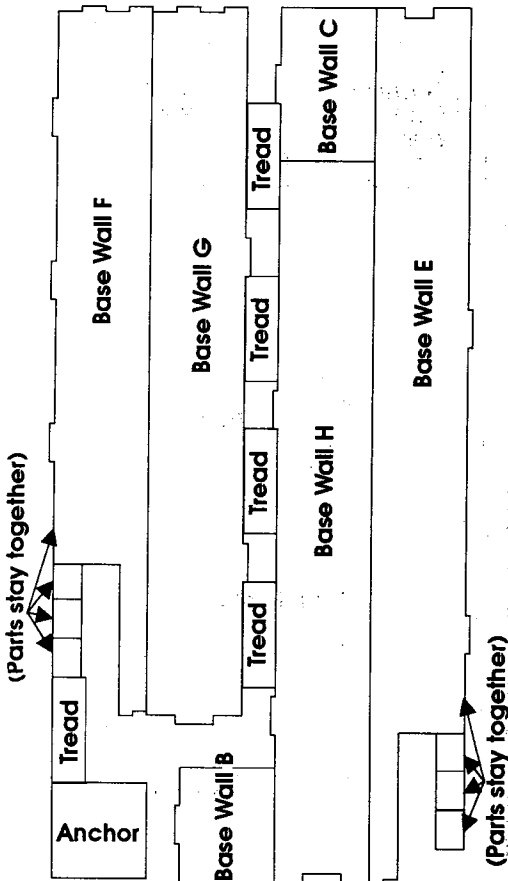

Sheet FH-20

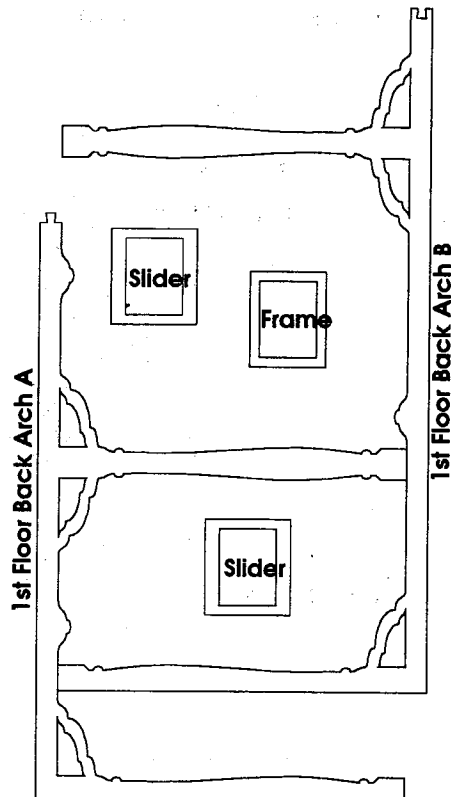

Sheet FH-21

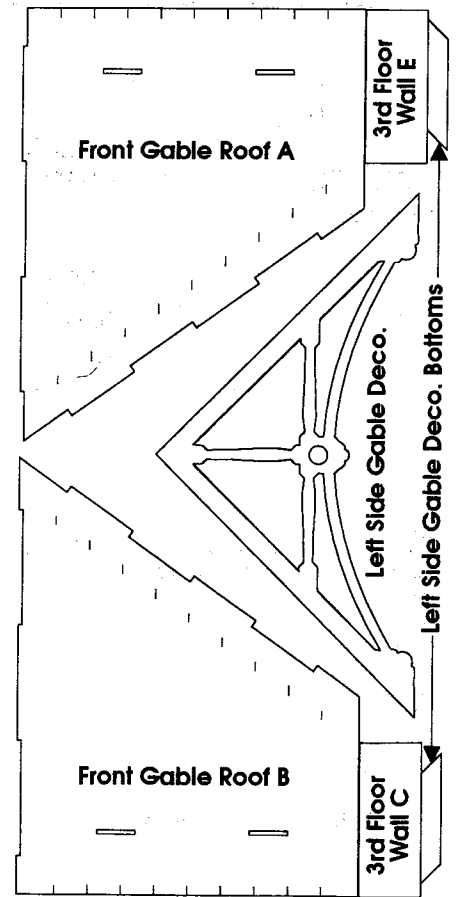

Sheet FH-22

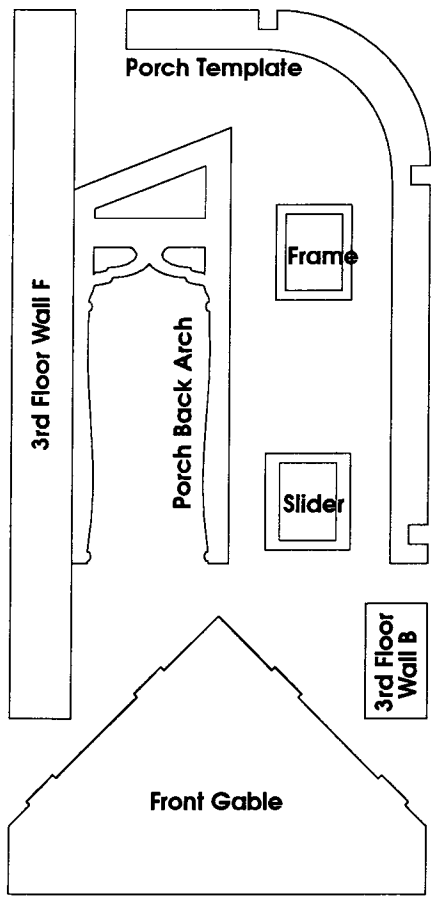

Sheet FH-23

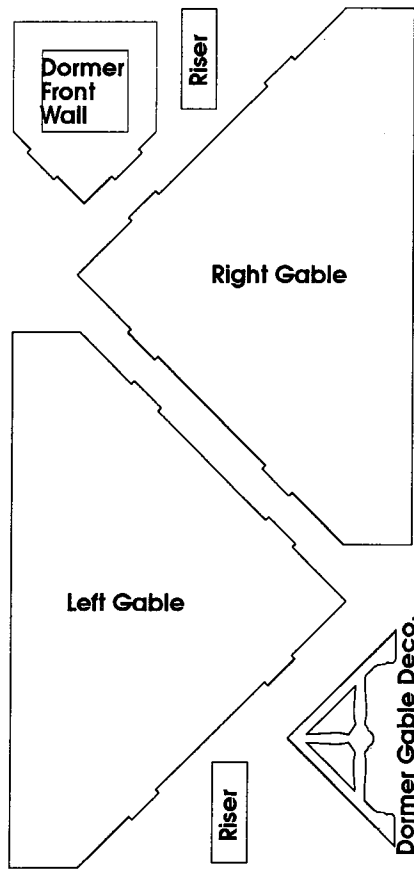

Sheet FH-24

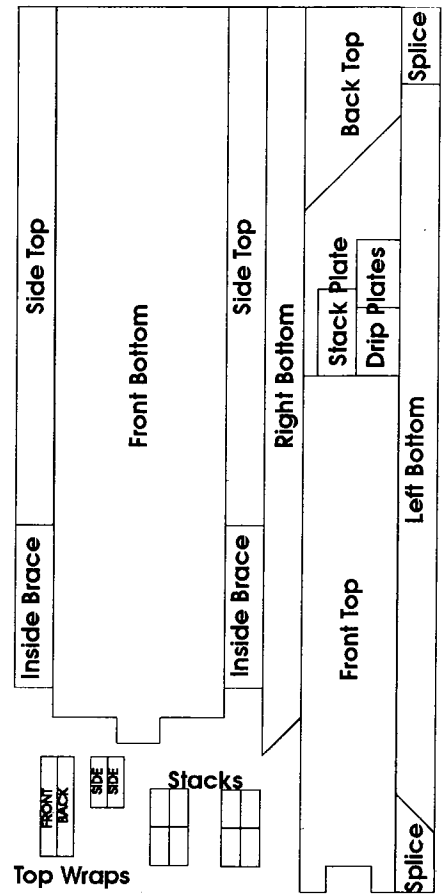

Sheet FH-25

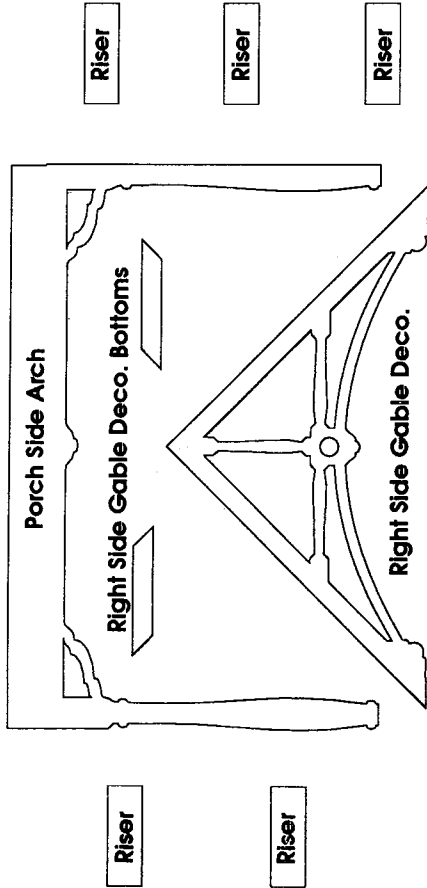

Sheet FH-26

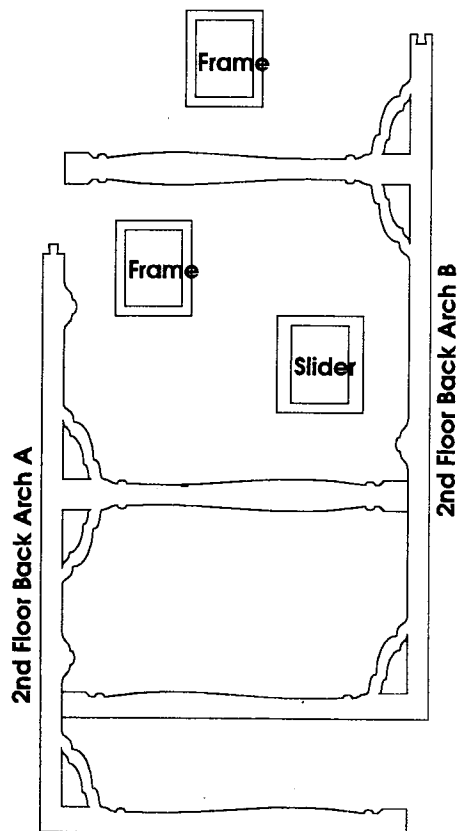

Sheet FH-27

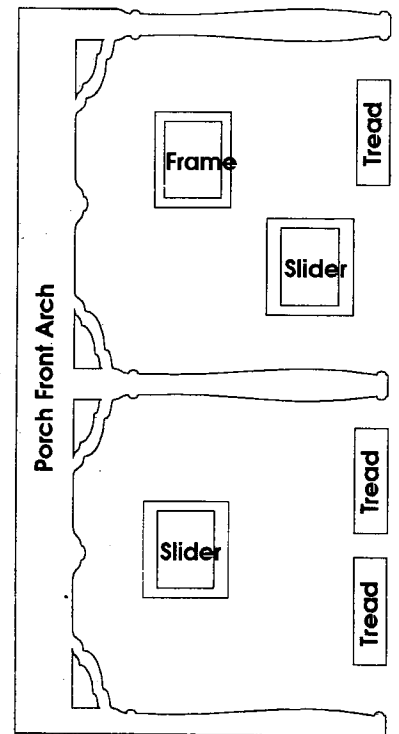

Sheet FH-28

WARRANTY

Buy this kit with confidence!

Dura-Craft, Inc. will guarantee each purchase with the necessary service and assistance to satisfactorily complete this kit. Damaged or missing parts will be replaced even if the damage is caused by improper assembly. This assistance will be supplied at no additional cost.

Dura-Craft, Inc.
P.O. Box 438
Newberg, OR 97132
(503) 538-3136

**MISSING AND BROKEN PARTS
REPLACEMENT FORM**

While we have done our very best to make sure that the kit you have purchased is complete and accurate, sometimes something goes wrong. We may have forgotten a piece, parts might have been damaged in freight, or you may have assembled it wrong. Dura-Craft policy has always been to replace parts at no charge, postage prepaid, no matter who was at fault. For our records though, please mark one of the following.

_____ MISSING _____ DAMAGED _____ ASSEMBLED WRONG

Name _____
Address _____
City, State _____ Zip _____
Phone() _____

Return this form to : DURA-CRAFT, INC.
P.O. BOX 438, NEWBERG, OREGON 97132

PLEASE USE THIS FORM FOR FAST AND ACCURATE SERVICE

| Building | Sheet No. | Quantity | Name of Part |
|----------|-----------|----------|--------------|
| | | | |
| | | | |
| | | | |
| | | | |
| | | | |
| | | | |
| | | | |

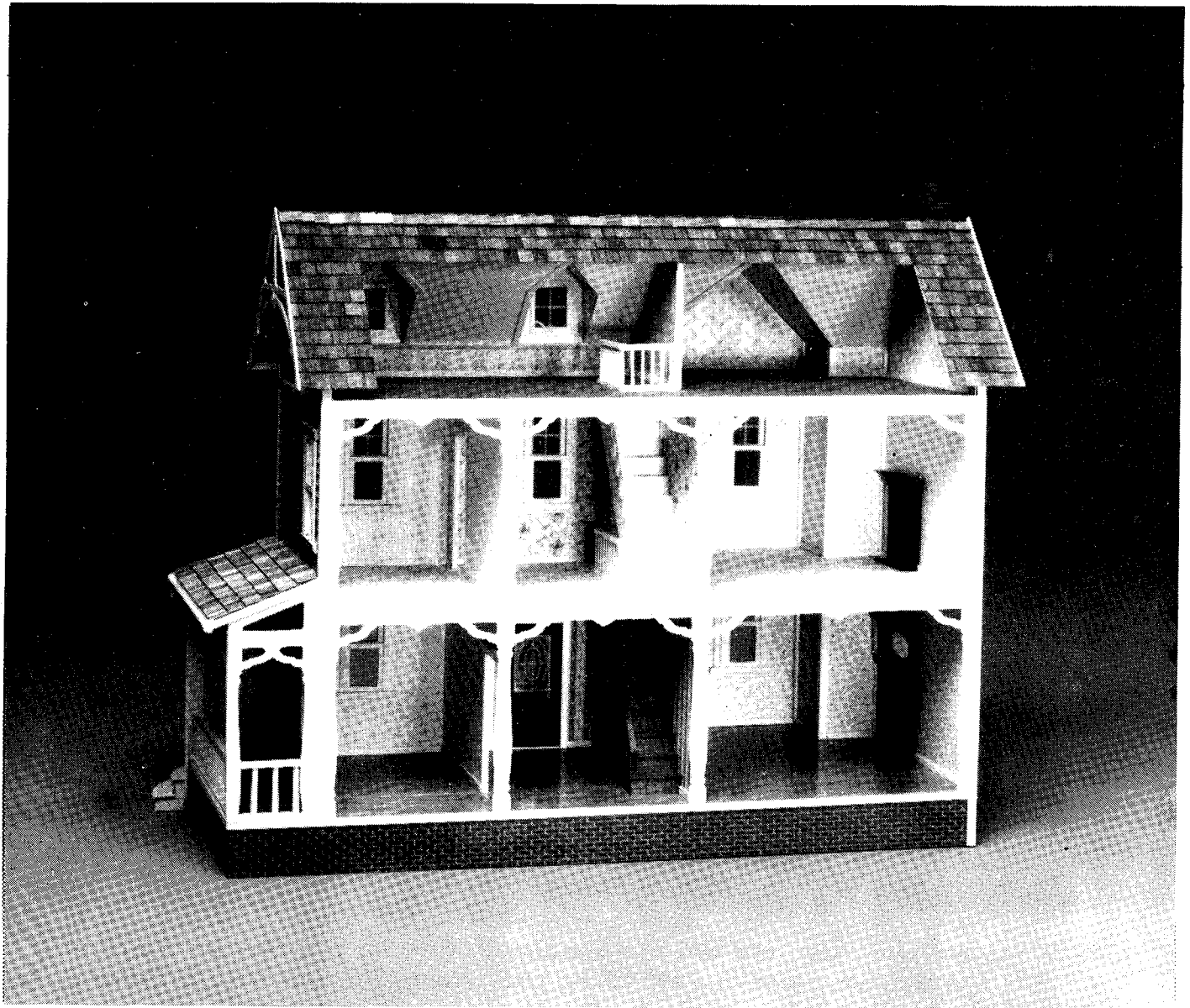

WARRANTY

Buy this kit with confidence!

Dura-Craft, Inc. will guarantee each purchase with the necessary service and assistance to satisfactorily complete this kit. Damaged or missing parts will be replaced even if the damage is caused by improper assembly. This assistance will be supplied at no additional cost.

Dura-Craft, Inc.
P.O. Box 438
Newberg, OR 97132
(503) 538-3136